



Aerospace Industry Support Initiative

an initiative of **the dtic**



2024/25

IMPACT REPORT



the dtic
Department:
Trade, Industry and Competition
REPUBLIC OF SOUTH AFRICA



CONTENTS

ABOUT AISI	04
AISI VISION AND MISSION	04
OVERVIEW OF AISI PROGRAMMES	06
AEROSPACE PRODUCT AND TECHNOLOGY MATRIX.....	08
BUDGET ALLOCATION BY PROGRAMME	09
PROJECTS SUMMARY IMPACTS AND BENEFITS FOR 2024/25 PERIOD	09
AEROSPACE AND DEFENCE: TECHNOLOGY-BASED SUPPLIER DEVELOPMENT	10
Autonosky: Development of the A22 Manqoba (Conqueror) Foldable High-performance UAV.....	12
Aero Services: Airborne Development of a Production Line for a UAV Project.....	14
Challenge Air: Airborne EMS (Emergency Medical Service) Life Support Station.....	16
Jan Hugo Precision Engineering: Hybrid Manufacturing of Airborne Observation System Components.....	18
Jonker Sailplanes: Aeroelastic Investigation of the JS-5 Sailplane and Flutter Flight Test Equipment Development ...	22
Tower35: Tower35 Stabilised Commander Sight (SCS) Pre-Production Update and Qualification.....	24
Dragonfly Aerospace: CFRP Sandwich Panel Development for Satellite Primary Structures.....	24

Aditiv Solutions: Validation of a Locally Manufactured HYRAX Metal 3D Printer to Produce Titanium Parts for the Defence (and Aerospace) Industries.....	26
Reutech Radar Systems: FMCW Short-Range Radar to Detect, Locate and Track Humans	28
Bronberg Dynamics: Development of a 12kg Minimum Take-off Weight (MTOW) Battery Powered UAV for Security Applications	30
Nablataq: Development of a VGA/XVGA Long Wave Infrared Thermal Imaging Core for Surveillance and Monitoring	32
Etion Create: Etion Autotracker Enhancement Development.....	34
HH Industries: Design and Integration of Additive Manufactured Parts for Turbojet Engines	36
SparcX: Radar Target Classification	38
LambdaG: Global Navigation Satellite System (GNSS) Antenna Development.....	40
AEROSPACE AND DEFENCE: STANDARDS AND ACCREDITATION	42
Shrike Marine: ISO 9001:2015	46
Luvhone Engineering: ISO9001 and ISO14001	47
Petrawell: Provision of Consulting Services to Implement ISO 9001:2015 QMS.....	48
AEROSPACE AND DEFENCE: INDUSTRY DEVELOPMENT AND TECHNOLOGY SUPPORT	
Ventura Engineering: Development and Localisation of Advanced Oil Coolers for Land-based Vehicles in the Defence Sector	52

LS Multicopter Projects and Services: Affordable Radio Frequency Direction-Finding Antenna Solution for band 20 MHz to 8 GHz in the Aerospace and Defence sector.....	54
Lightweight Structures: Composite Moulding Process Development for Complex Radome Enclosure	56
Radar Makers: Passive Radar Compact Antenna Enhancement	58
Kusasa Aerospace: Drone Payload Delivery System Project	60
AAC Space Africa: Wide-band S-band Antenna for CubeSat TMTC Application.....	62
OnTrack Technologies: Rear Electrical Propulsion System	64
Avior Labs: Industrialisation and Commercialisation of the Elevation Drone	66
Simera Sense: CubeSat Shock Test Facility Project.....	68
Micromax: Metal Injection Proof of Concept at Micromax Project	70
WBRxS: Technology Enhancement: From Wide Band Receiver to Wideband Transceiver.....	72
SECTOR WIDE ACCREDITATION PROGRAMME: TECHNOLOGY ENHANCEMENT.....	74
Ulmo Water: Modular Dissolved Air Flotation Reactor Product Development	76
Skills Instruments: Manufacturing Minimal Invasive Cardiac Instruments	78
Feasible Plastics: Tooling for Large Injection Moulded Bolt & Nut for Floating Solar Assembly	80

SECTOR WIDE: STANDARDS AND ACCREDITATION 82	
Nicro Pump and Valve: ISO 9001 and SABS Certification for Valves	84
New Vision Engineering: ISO 9001, ISO 14001 and ISO 45001 Implementation	85
Khentsa Specialised Tube: ISO 9001:2025 Quality Management System	85
MARINE: TECHNOLOGY ENHANCEMENT	86
Icarus Marine: Hydrofoil Flap Control System	88
KND Design: High Density Polyethylene (HDPE) Boat Project.....	90
HopYacht: Building Production Capacity for Export Sales.....	92
IBIS Manufacturing: Rubber Pilot Step Ladder Manufacturing Process.....	94
Symbytech: Argonót Development of an Underwater UAV.....	96
MARINE: STANDARDS AND ACCREDITATION	98
Naude Industries: ISO3834 Welding Quality System....	101
Polyfix: ISO 9001, ISO 12944-5, ISO 14001 and CORISSA Training	101
Surcotech: Thermal Spray Certification.....	102
Prostar Paints: Implementation of ISO 17025 and Type Approval of Paint and Facilities.....	103
Carbontech: ABS Approved Carbon Fibre Pipe Repair Schemes	104
COORDINATION, PROMOTION AND AWARENESS.....	106

ABOUT AISI

The Aerospace Industry Support Initiative (AISI) is a national industrial development programme of the Department of Trade, Industry and Competition (**the dtic**), hosted and managed by the Council for Scientific and Industrial Research (CSIR). It seeks to strengthen the global competitiveness of South Africa’s aerospace, defence, marine and advanced manufacturing sectors.

Through targeted interventions, the AISI supports technology development, supplier capability enhancement, standards and accreditation attainment, and sector-wide collaboration to grow the country’s industrial base. Its programmes focus on integrating SMMEs into high-technology value chains, fostering innovation, facilitating skills transfer, and aligning industry growth with national economic priorities such as transformation, localisation, and export expansion.

The AISI plays a pivotal role in advancing industrial modernisation, supporting strategic sector development, and positioning South Africa as a trusted producer of world-class, technology-driven products and services in the global market.

In presenting this Impact Report for 2024/25, the AISI management extends its gratitude to **the dtic**, the local aerospace, defence and marine and other advanced manufacturing industries, the AISI team, and its host organisation, the Council for Scientific and Industrial Research (CSIR).

AISI VISION AND MISSION

VISION

To position South African aerospace-, defence-, marine- and other advanced manufacturing industries as global leaders, in niche areas.

MISSION

To enhance the global competitiveness of the South African aerospace, defence, marine and other advanced manufacturing industries by:

- Developing relevant support to industry focused capabilities and facilitate associated transfer of technology to industry.
- Identifying, supporting and promoting the interests and capabilities of the South African aerospace, defence, marine, and other advanced manufacturing industries.
- Implementing industrial policies in support of government strategic objectives including economic growth, exports, localisation, employment, transformation and equity.
- Contribute towards activities addressing de-industrialisation and increasing manufacturing value addition.

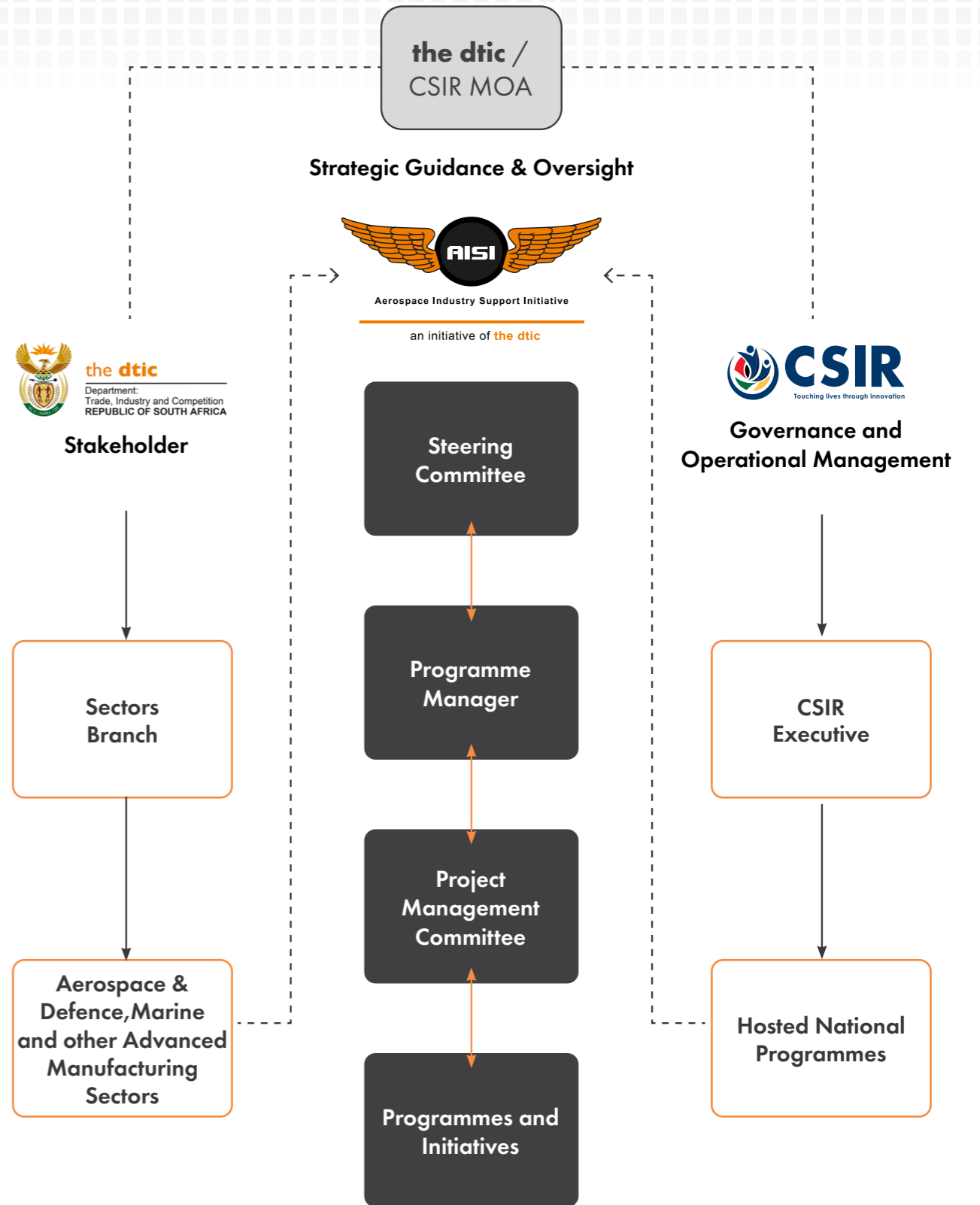

The AISI is an initiative of **the dtic** which is hosted and managed by the CSIR Hosted National Programmes. The AISI is managed to adhere to the Public Finance Management Act (PFMA), within the CSIR’s procedural and policy framework. The AISI operating structure is shown in the figure above.

OVERVIEW OF AISI PROGRAMMES

Since 2006, the AISI has enabled **the dtic** to achieve the following sectoral development goals:

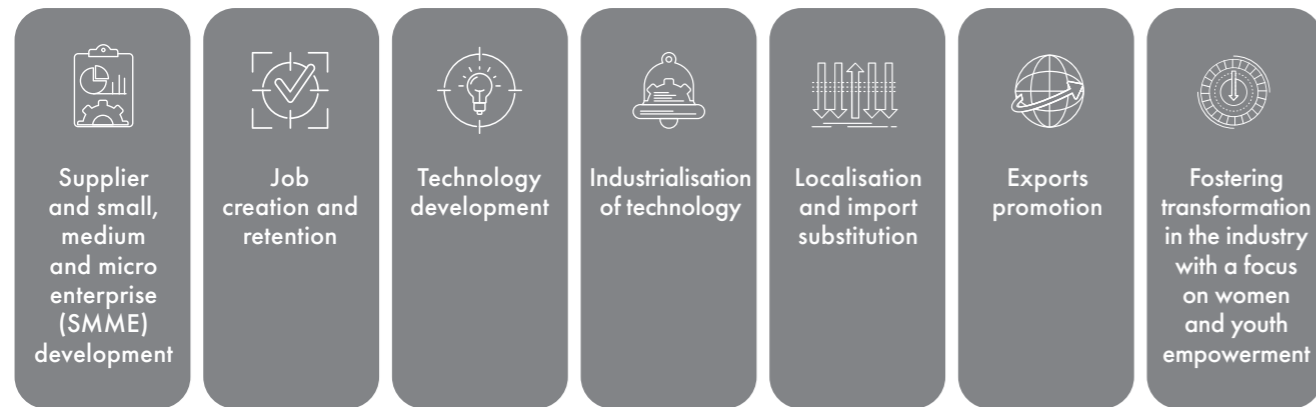

These goals are achieved through the implementation of programme level interventions within specific technology streams and product markets. The AISI utilises relevant tools such as technology road mapping to facilitate the development of technology strategies for respective AISI beneficiaries. This enables the AISI to identify specific interventions within its mandate to assist in improving the competitiveness of local industry.

The five AISI programmes, that support the implementation of the AISI mandate, are designed to assist industry in overcoming challenges, building local capabilities and technological solutions, and enhancing global competitiveness.

1 TECHNOLOGY-BASED SUPPLIER DEVELOPMENT

This programme equips South African SMMEs and lower-tier suppliers with the capabilities to participate in high-technology value chains by improving productivity, implementing quality management systems, optimising operations, and facilitating integration into global supply chains.

It encourages collaboration between original equipment manufacturers (OEMs), integrators, and emerging enterprises through targeted technical support, mentoring, and technology upgrades. This initiative is central to transformation in the aerospace, defence, and advanced manufacturing sectors, enabling historically disadvantaged businesses to meet stringent international standards and evolve from component suppliers into innovation partners, thereby driving inclusive industrialisation and export competitiveness.

2 INDUSTRY DEVELOPMENT AND TECHNOLOGY SUPPORT

The Industry Development and Technology Support programme advances production innovation by promoting the use of advanced manufacturing and Fourth Industrial Revolution (4IR) technologies to produce more durable, efficient, and competitive products. It facilitates access to new and existing processes, products, and methods, while encouraging the integration of SMMEs into technology-rich supply chains to ensure continuous knowledge transfer and capability building.

In the South African context, the programme is a driver of industrial modernisation, helping manufacturers in sectors such as aerospace, defence, automotive, and marine adopt automation, additive manufacturing, advanced materials, and digital design tools, improving product quality, reducing costs, and enhancing global market readiness.

3 SECTOR STRATEGIC SUPPORT INITIATIVES

The AISI's Sector Strategic Support Initiatives programme oversees and contributes to projects of national importance, such as developing the Commercial Aviation Industry Development Strategy, hosting the Joint Aerospace Steering Committee, and contributing to the Aerospace and Defence Masterplan.

These initiatives ensure that the growth of strategic industries is coordinated, sustainable, and aligned with South Africa's national economic priorities, fostering collaboration between government, industry, and academia. By identifying niche opportunities for specialisation, export growth, and supply chain development, this programme positions South Africa as a competitive global player while enabling innovation, skills development, and long-term sector sustainability.

4 SECTOR-WIDE ACCREDITATION

The Sector-Wide Accreditation programme supports companies in achieving internationally recognised quality, safety, and performance certifications while enhancing their technological capabilities. By assisting businesses, particularly SMMEs, to comply with global and sector-specific standards, the programme strengthens market access, operational efficiency, and competitiveness.

In South Africa, it is a key driver for industrial growth and transformation, enabling local suppliers to integrate into high-value global supply chains, improve product quality, and build a reputation for delivering world-class, technology-driven solutions in industries such as aerospace, defence, and marine.

5 COORDINATION, PROMOTION AND AWARENESS

The Coordination, Promotion and Awareness programme plays a vital role in aligning activities across the sectors represented by the AISI and raising awareness of South Africa's industrial capabilities. Through flagship events such as the annual Aeronautical Society of South Africa Conference, it provides a platform for industry, government, academia, and research institutions to showcase projects, share knowledge, and strengthen collaborative networks.

These activities not only enhance the visibility of South African innovations and manufacturing excellence both locally and internationally but also attract investment, create market opportunities, and inspire new talent to join high-technology industries, supporting long-term sector growth and sustainability.

AEROSPACE PRODUCT AND TECHNOLOGY MATRIX

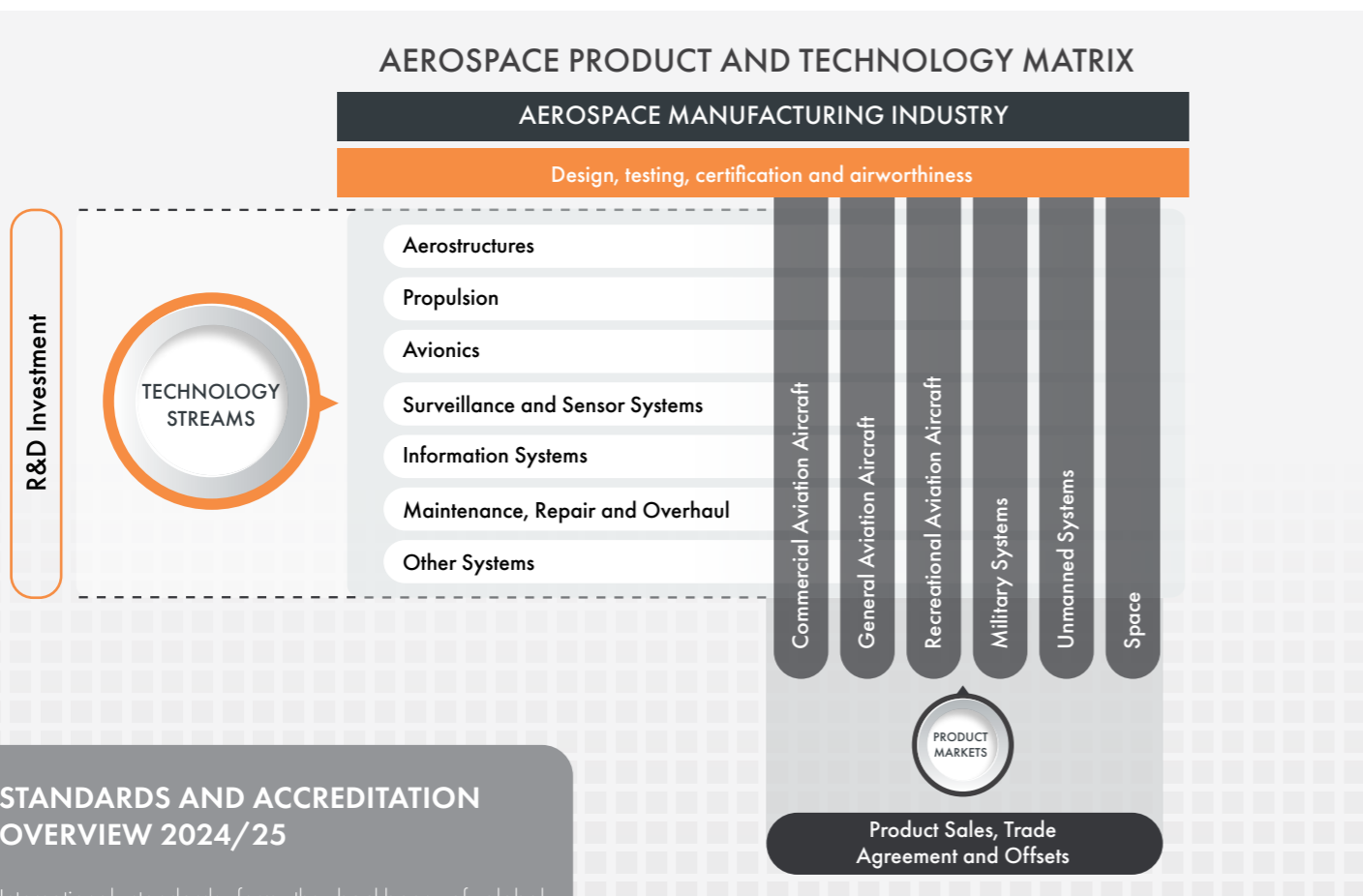

STANDARDS AND ACCREDITATION OVERVIEW 2024/25

International standards form the backbone of global trade and innovation, providing a common language that transcends borders, industries, and cultures. By defining clear benchmarks for product safety, performance, and interoperability, they ensure that goods and services meet consistent expectations regardless of where they are produced or consumed. This not only protects consumers from harmful or substandard products but also builds trust between suppliers and buyers.

Beyond ensuring quality and safety, international standards increasingly incorporate principles of sustainability, social responsibility, and ethical governance. They encourage businesses to minimise environmental impact, optimise resource use, and uphold fair labour practices throughout their supply chains.

By embedding these values into manufacturing and service delivery, standards help align economic growth with global sustainability goals, fostering innovation that benefits both people and the planet. In this way, they transform consumer choice into a vehicle for positive change, ensuring that excellence in performance goes hand in hand with a commitment to environmental stewardship and social well-being.

- Marine and other Accreditation and Certifications
- Testing and Calibration Certification
- Quality Management
- Safety
- Product Development
- Environmental Management
- Occupational Health and Safety Management

BUDGET ALLOCATION BY PROGRAMME

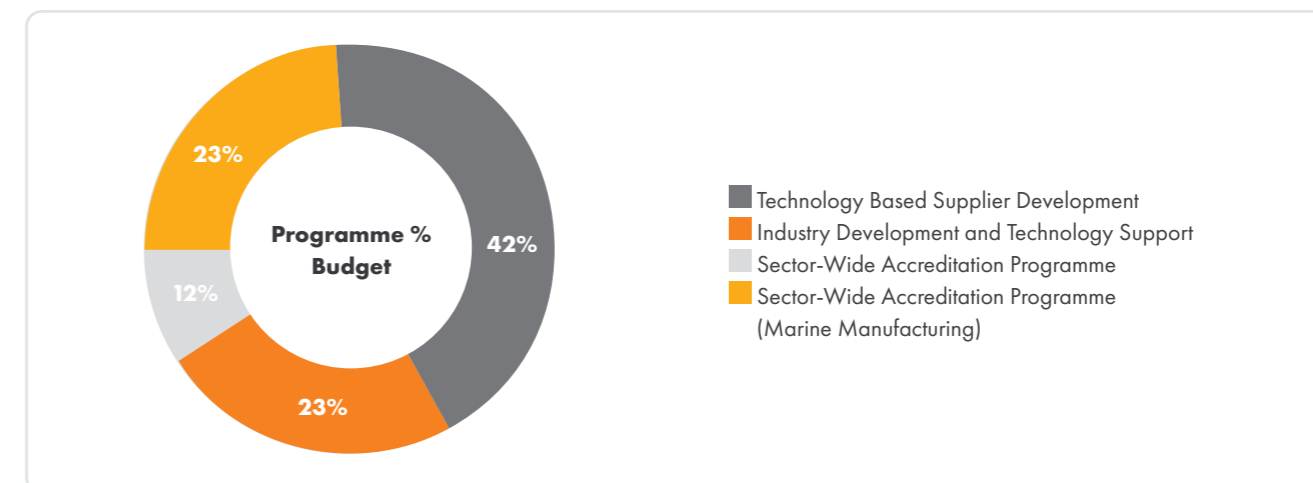

PROJECTS SUMMARY IMPACTS AND BENEFITS FOR 2024/25 PERIOD

- 835 no. of jobs supported by AISI interventions
- R 24.9m investment facilitated by the AISI
- 61 total no. of projects supported
- 13 industry development and technology support projects
- R 26.83 million additional local industrial output as a result of AISI interventions
- 68 no. of new jobs created by AISI interventions
- 58 no. of beneficiaries supported
- R 18.7m manufacturing exports achieved through AISI interventions
- 445 no. of jobs supported by AISI interventions at black industrialist beneficiaries
- R24.35m support programmes administered by the AISI to improve competitiveness, expand industrialisation and create jobs benefiting SMMEs
- 19 technology-based supplier development projects
- 15 technology enhancement projects
- 14 standards and accreditation projects
- 1 support for programmes to improve competitiveness, expand industrialisation and create jobs



AEROSPACE AND DEFENCE

TECHNOLOGY-BASED SUPPLIER DEVELOPMENT

Technology enhancement is vital for South Africa as it drives economic growth, global competitiveness, and social development by enabling industries to innovate, improve productivity, and produce higher-value goods and services. Advancing technological capabilities supports industrial modernisation, facilitates participation in global value chains, and strengthens key sectors.

It also addresses structural challenges, including unemployment and skills shortages, by creating demand for specialised expertise and fostering new job opportunities in high-growth, knowledge-based industries. Moreover, technology enhancement underpins solutions to pressing national priorities, from renewable energy adoption and infrastructure resilience to improved healthcare delivery and sustainable resource management. This ensures that South Africa can adapt and thrive in an increasingly digital, interconnected, and competitive world.

- Autonosky:** Development of the A22 Manqoba (Conqueror) Foldable High-Performance UAV
- Aero Services:** Airborne Development of a Production Line for a UAV Project
- Challenge Air:** Airborne EMS (Emergency Medical Service) Life Support Station
- Jan Hugo Precision Engineering:** Hybrid Manufacturing of Airborne Observation System Components
- Jonker Sailplanes:** Aeroelastic Investigation of the JS-5 Sailplane and Flutter Flight Test Equipment Development
- Tower35:** Tower35 Stabilised Commander Sight (SCS) Pre-Production Update and Qualification
- Dragonfly Aerospace:** CFRP Sandwich Panel Development for Satellite Primary Structures
- Aditiv Solutions:** Validation of a Locally Manufactured HYRAX Metal 3D Printer to Produce Titanium Parts for the Defence (and Aerospace) Industries
- Reutech Radar Systems:** FMCW Short-Range Radar to Detect, Locate and Track Humans
- Bronberg Dynamics:** Development of a 12kg Minimum Take-off Weight (MTOW) Battery Powered UAV for Security Applications
- Nablateg:** Development of a VGA/XVGA Long Wave Infrared Thermal Imaging Core for Surveillance and Monitoring
- Etion Create:** ETION Autotracker Enhancement Development Project
- HH Industries:** Design and Integration of Additive Manufactured Parts for Turbojet Engines
- Sparcx:** Radar Target Classification
- LambdaG:** Global Navigation Satellite System (GNSS) Antenna Development

AUTONOSKY

Development of the A22 Manqoba (Conqueror) Foldable High-performance UAV

The A22 Manqoba project by AutonoSky represents a transformative leap in the unmanned aerial vehicle (UAV) sector, addressing long-standing limitations around portability, modularity, and artificial intelligence (AI) readiness. Unlike traditional drones constrained by bulky designs and limited adaptability, the A22 Manqoba offers a next-generation platform that is foldable, modular, and engineered for rapid deployment.

Amit Ramdath, CEO of AutonoSky describes some key advantages of the UAV: "Its compact design allows for easy transport in a standard backpack, enabling swift deployment in mission-critical environments such as defence operations, disaster response, and logistical support. The modular payload system allows users to adapt the drone for various functions, from surveillance and reconnaissance to cargo delivery, eliminating the need for multiple UAV systems and reducing both procurement and maintenance costs."

At the core of its innovation is an AI-ready architecture designed to accommodate future advances in autonomous navigation, real-time decision-making, and swarm coordination. The drone is equipped with custom flight control hardware and secure frequency-hopping radios to maintain signal integrity in congested or contested areas. These features make the A22 Manqoba not just an advanced UAV for current missions but a future-proof investment for clients seeking to stay ahead in fast-evolving operational landscapes. Its adaptability and intelligent infrastructure position it as a high-performance platform capable of evolving alongside the demands of modern aerial missions.

The project responds directly to several national priorities, which prompted the AISI to support its development. The A22 Manqoba project contributes meaningfully to South Africa's aerospace industry by fostering local intellectual property, building in-house high-tech manufacturing capacity, and promoting skills development. This focus on domestic innovation supports broader national objectives around industrialisation, digital transformation, and global competitiveness.

“

The A22 Manqoba redefines UAV technology with its foldable, modular design and AI-ready architecture, making it a future-proof solution for defence, disaster response, and logistics. More than a drone, it's a catalyst for South Africa's aerospace innovation and industrialisation.”

Through its rigorous design, development, and testing processes, AutonoSky is delivering a UAV solution that is not only operationally effective today but also primed to meet the challenges of tomorrow's autonomous and AI-driven environments.

About AutonoSky

AutonoSky is a South African aerospace technology company dedicated to developing advanced UAV platforms that combine cutting-edge engineering with modular, AI-ready systems. With a strong focus on innovation, the company aims to deliver adaptable drone solutions that meet the evolving needs of defence, logistics, and disaster management sectors. AutonoSky's flagship project, the A22 Manqoba, exemplifies this vision through its compact, foldable design, modular payload capabilities, and future-proof infrastructure designed to support autonomous operations and swarm technologies.

Driven by a commitment to local innovation and industrial growth, AutonoSky is actively contributing to the development of South Africa's high-tech manufacturing ecosystem. By creating proprietary UAV technologies and establishing in-house design and production capabilities, the company not only enhances its competitive edge but also supports skills development and economic empowerment within the country. AutonoSky is positioning itself as a leader in the next generation of UAV solutions, versatile, intelligent, and built for real-world impact.

PROJECT IMPACT

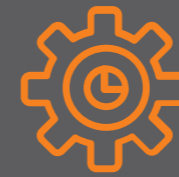

Versatile and Cost-efficient:
Foldable, modular design for multi-mission use with reduced costs.

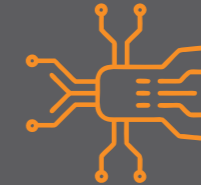

Future-ready Tech:
AI-capable architecture with secure, advanced flight systems.



Local Impact:
Builds SA IP, manufacturing capacity, and skills development



Inyeni Showers (left) and Adam Mbombole (right) are seen here assembling an Autono 1 heavy-lift multirotor

AERO SERVICES

Airborne Development of a Production Line for a UAV Project

Aero Services is a South African aerospace manufacturing firm specialising in large-scale drone airframes with a wingspan of approximately 3.5 meters. The company employs advanced composite techniques, including carbon fibre and fibreglass layups, sandwich panel integration, and precision hand trimming, to produce high-performance airframes.

Managing the entire production cycle in-house, from assembly to spray painting Aero Services has completed four prototypes (with two more in development), all of which have passed static and flight testing. These milestones provide a strong foundation for scaling up manufacturing operations and transitioning to full industrialisation.

With current production capacity at one airframe per month, Aero Services aims to increase output of 3 to 4 units per month, marking a 300 - 400% improvement. Achieving this goal involves strategic investments in refining moulds, tooling, and fixturing, enhancing composite layup and trimming techniques (including the introduction of robotic trimming), optimising material choices, and applying lean manufacturing principles.

This scale-up is essential to meeting growing global demand for unmanned aerial vehicles (UAVs) while ensuring cost efficiency, high profit margins, and consistent quality. Notably, the NRAVEN drone platform, developed in partnership with Paramount Aerospace Systems (PAS), is designed to address the surge in demand for scalable drone solutions amid rising global instability and asymmetric warfare.

In addition to its growing NRAVEN project, PAS is fulfilling contracts for ALSTOM (locomotive toilet cubicles) and Embraer (aircraft interior conversions), with a 24-month order pipeline reflecting sustained demand. Anticipating a need for up to 2 000 NRAVEN airframes annually, the company, with support from the AISI, is developing an industrialised production line capable of meeting this target within six months.

This effort is underpinned by South Africa's cost-effective labour, agile manufacturing environment, and a young, trainable workforce, positioning the country as a competitive player in the global aerospace market, particularly in the mass production of advanced unmanned aerial systems.

“

Aero Services is scaling up from one to four drone airframes per month, using advanced composites and lean manufacturing to meet surging global demand. With the NRAVEN platform, South Africa is positioning itself as a competitive force in mass UAV production.”



Fuselage development



PROJECT IMPACT



Scaled Production:
Expands output from 1 to 3-4 UAVs per month, enabling mass production.



Global Competitiveness:
Meets rising demand for UAVs with cost-efficient, high-quality manufacturing.



Local Growth:
Builds SA's aerospace capacity, creating jobs and skills in advanced composites.

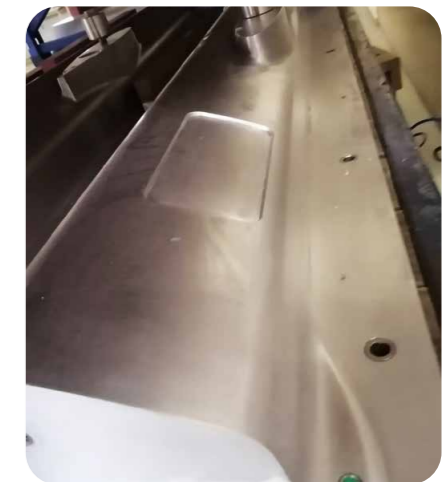

Fuselage development processes

CHALLENGE AIR

Airborne Emergency Medical Service Life Support Station

Challenge Air International (Pty) Ltd is a long-established South African aerospace engineering firm, operating since 1996 and now recognised as a South African Civil Aviation Authority (SACAA) approved Part 147 Design Organisation. With a portfolio that spans aircraft maintenance, design modifications, and manufacturing of aeronautical components, the company has evolved into a critical service provider for both domestic and international aerospace stakeholders.

Leveraging its diverse experience and highly skilled team, Challenge Air has become a go-to partner for producing data packs, kits, and custom modifications in mechanical, structural, and avionics systems. Its reach extends across the Southern African Development Community (SADC) region and abroad, and it is actively pursuing AS9100 certification to strengthen its global competitiveness.

“In response to industry needs, Challenge Air identified a major challenge in the airborne Emergency Medical Service (EMS) sector: the lack of flexibility in EMS life-support systems, which are typically installed through aircraft-specific modifications. These static installations restrict the transferability of equipment between airframes, limiting operational responsiveness when aircraft are undergoing maintenance or reassigned, comments name, designation at Challenge Air. “Having recognised this as a bottleneck, Challenge Air set out to propose an innovative solution in the form of a portable, self-contained EMS life-support kit that eliminates the need for aircraft modifications and can be rapidly transferred between helicopters and fixed-wing aircraft.”

The project aims to convert concept designs into a fully developed, commercially viable product that meets the airborne EMS industry’s rigorous standards. This battery-powered kit will be compact, lightweight, energy-efficient, and capable of providing integrated life-support functionality within the tight confines of EMS aircraft cabins. Charging flexibility via aircraft power, wall socket, or interchangeable battery packs will enhance its operational usability. A dedicated operator application (APP) will later be developed to monitor power status and facilitate user interaction. To ensure relevance to operational needs, Challenge Air will draw on its past EMS projects and conduct further customer engagement through surveys and feedback.

Not only will this initiative address a critical gap in the market, but it will also provide a platform for upskilling young South African engineers and technicians, boosting local capability in aerospace manufacturing and product innovation.

Ultimately, the EMS Life-support kit project exemplifies Challenge Air’s commitment to impactful innovation within the aviation sector. It presents a high-potential opportunity to strengthen South Africa’s role in the global aerospace industry by delivering a locally designed and manufactured solution that meets international standards. The kit’s flexibility will allow operators to scale up operations more efficiently, improve emergency medical response capabilities, and reduce downtime associated with aircraft configuration. This project represents a meaningful step forward in both health-sector aviation support and local industrial growth.



Portable Emergency Medical Service (EMS) kit with basic life support equipment, including oxygen, vacuum, and power outlets in support of ad-hoc aircraft emergency medical operations. The dimensions of the EMS kit are mandated by the space available in the helicopters where they would most likely be installed

PROJECT IMPACT



Operational Flexibility:
Portable EMS kit enables rapid transfer between aircraft, reducing downtime and boosting responsiveness.



Market Innovation:
Delivers a compact, energy-efficient, battery-powered life-support system meeting global standards.

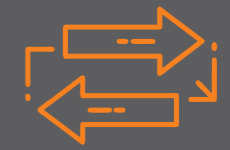

Local Capacity:
Strengthens SA aerospace skills, manufacturing, and product innovation.

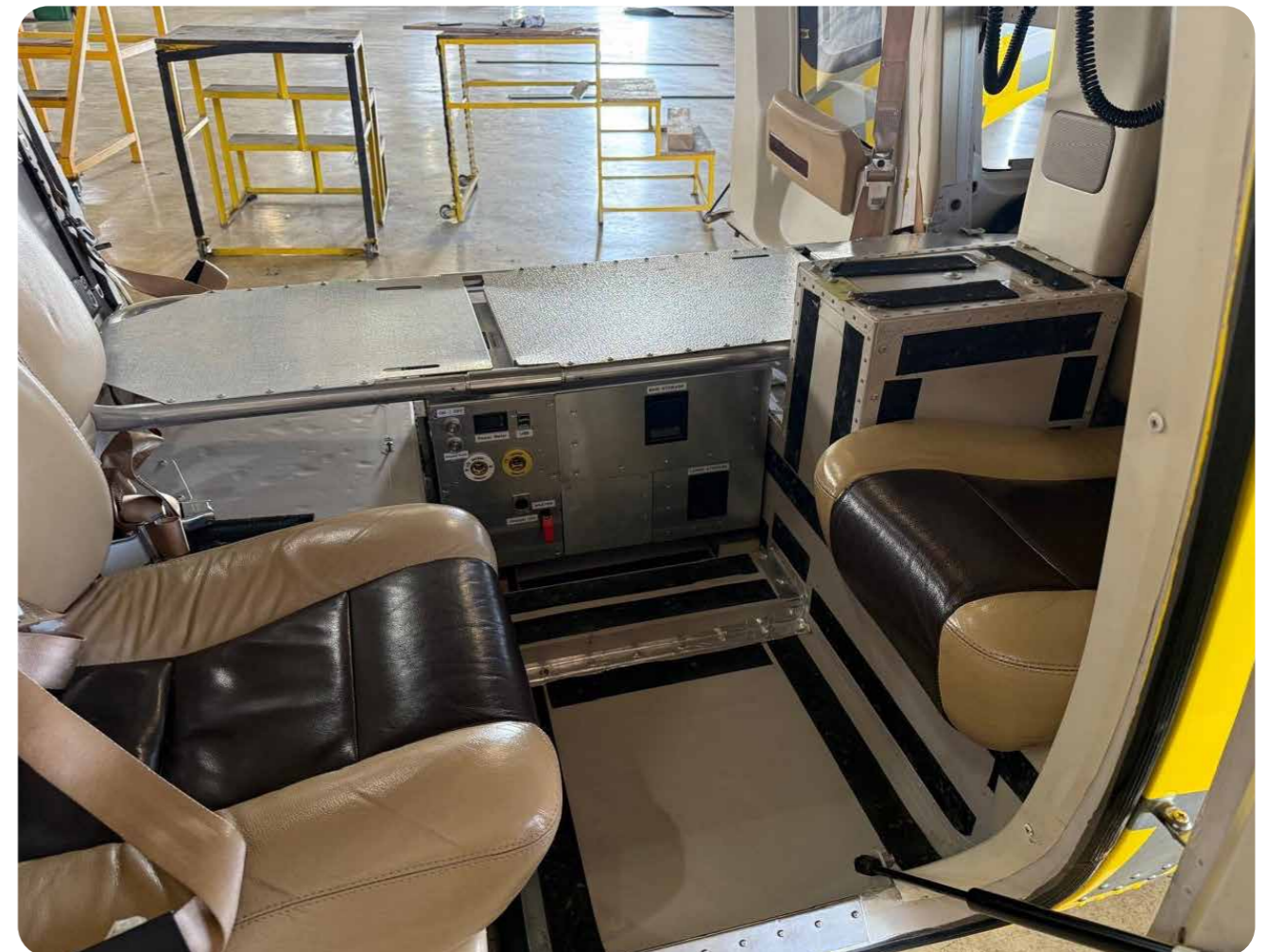

The life support station designed addresses the challenge associated with static installations that restrict the transferability of equipment between airframes.

JAN HUGO PRECISION ENGINEERING

Hybrid Manufacturing of Airborne Observation System Components

The collaborative project between the Council for Scientific and Industrial Research (CSIR), Jan Hugo Precision Engineering (JHPE), and Hensoldt Optronics (Pty) Ltd has been launched with a clear and ambitious goal: to demonstrate the feasibility of reducing lead times in the manufacturing of airborne observation system components through the integration of Metal Additive Manufacturing (MAM) with precision Computer Numerical Control (CNC) machining. This partnership is designed to explore hybrid manufacturing solutions that will enable faster, more efficient, and more precise production of components vital to the performance of electro-optical systems. While all three partners bring unique capabilities to the project, Jan Hugo Precision Engineering's role is particularly pivotal in proving how advanced local precision engineering expertise can unlock innovation for global aerospace applications.

At the centre of the initiative is Hensoldt Optronics, a global leader in designing and producing electro-optical systems (EOS) and high-precision engineered products for both defence and non-defence applications. Hensoldt's airborne observation technologies are deployed across platforms such as UAVs, fixed-wing aircraft, and helicopters, where extremely high precision mechanics are required for stabilised gimbal assemblies and sensor systems. The company faces ongoing challenges with extended lead times for key components, often due to the need for suppliers to establish bespoke processes before delivering production-ready parts. This project directly addresses that challenge by leveraging the combined expertise of JHPE in CNC machining and CSIR in additive manufacturing research, enabling Hensoldt to meet its customers' demands more efficiently.

Jan Hugo Precision Engineering, a trusted supplier to Hensoldt Optronics, is taking the lead in implementing the hybrid approach. Known for its specialisation in high-tolerance CNC machining, JHPE is pioneering the integration of MAM into its production chain. Traditionally, critical optical components have been produced exclusively through machining, a process that is highly accurate but time-intensive. JHPE's innovation lies in

using MAM to produce near-net-shape parts with complex geometries and then applying CNC machining to refine critical interfacing surfaces. This approach preserves the accuracy and stability required for optical alignment while significantly reducing production times, offering a potential paradigm shift in aerospace component manufacturing.

The project is centred on three components for Hensoldt's next-generation Airborne Observation System: the Frame Rail Base, the Frame, and the Optical Bench for Targeting. Each of these parts demands exceptional dimensional accuracy and stability, with tolerances that leave no margin for error. JHPE is leading the development of the hybrid manufacturing process, which involves multiple printing iterations and design reviews. The Frame Rail Base and Frame will each undergo three printing cycles to refine parameters, while the Optical Bench will require one iteration.

Ultimately, the project serves as a proof-of-concept for the future of hybrid manufacturing in South Africa's precision engineering sector. If successful, it will not only help Hensoldt reduce lead times and improve responsiveness to market demands but also strengthen South Africa's industrial base by showcasing how local suppliers like JHPE can deliver globally competitive, high-precision solutions. The benefits extend beyond the aerospace and defence sectors, opening pathways for innovation in maritime, automotive, and advanced manufacturing. By driving skills transfer, supplier development, and the adoption of next-generation production technologies, the initiative promises to contribute significantly to South Africa's industrial competitiveness, with Jan Hugo Precision Engineering at the forefront of this transformative journey.



CSIR's role in the collaboration is critical, particularly in the process development phase. Their expertise in developing printing parameters, conducting density measurements using the Archimedes method, and optimising relative density ensures that the MAM process achieves high material quality and structural integrity.

These contributions provide the scientific and technical foundation that allows JHPE to confidently apply additive manufacturing in a highly demanding environment. Together, CSIR's research capability and JHPE's engineering expertise form a powerful combination that can meet the exacting standards required by Hensoldt Optronics and its global customers.



PROJECT IMPACT



Reduced Lead Times: Hybrid manufacturing combining Metal Additive Manufacturing (MAM) and CNC machining significantly shortens production cycles for critical airborne observation components.



Enhanced Local Capability: Strengthens South Africa's precision engineering sector by proving the feasibility of advanced hybrid manufacturing, reducing reliance on imported parts.



Industry Competitiveness: Improves Hensoldt's ability to respond to customer needs while positioning Jan Hugo Precision Engineering and CSIR as leaders in innovation for aerospace and defence supply chains.



Design modifications are guided by CAD model reviews, visual inspections, and precision measurements, ensuring that final versions meet stringent aerospace requirements

JONKER SAILPLANES

Aeroelastic investigation of the JS-5 sailplane and flutter flight test equipment development.

The flutter clearance of the JS5 glider marked a significant milestone for both Jonker Sailplanes (JS) and the Council for Scientific and Industrial Research (CSIR), driving innovation in glider-specific flutter analysis and testing technologies. As the latest high-performance model from JS, the JS5 plays a critical role in the company's continued international growth and export potential. The CSIR's involvement enabled it to refine and validate its specialised flutter testing methodologies, overcoming unique challenges posed by gliders, such as low natural frequencies and sensitivity to mass and aerodynamic disturbances, that differ markedly from those of conventional aircraft.

To address these challenges, CSIR developed a suite of advanced tools including a vacuum suspension system to eliminate suspension stiffness interference during ground vibration tests (GVT) and a long-stroke pneumatic exciter capable of achieving the necessary amplitudes.

Additionally, the introduction of a lightweight rotating annular wing exciter for in-flight testing enabled effective excitation with minimal impact on glider flight dynamics. These innovations, first trialled

on the JS2 and deployed on the JS5, significantly enhanced the accuracy and safety of flutter testing. The project also saw the reuse of a GSM-based telemetry system, allowing real-time transmission of test data from aircraft to ground engineers, streamlining the testing process and improving safety and decision-making.

The successful flutter clearance of the JS5 not only paves the way for full-scale production but also affirms the strength of South African aerospace engineering. For Jonker Sailplanes, a growing SME with over 500 gliders delivered globally, this achievement supports job creation, export growth, and international competitiveness.

For CSIR, the project validated a robust suite of tools for lightweight aircraft testing and solidified its role in supporting light aviation innovation. More broadly, this collaboration between a cutting-edge aerospace manufacturer and a national R&D institution highlights the value of local innovation, technical excellence, and public-private partnerships in advancing the aerospace sector and reinforcing South Africa's standing in global aviation.

Why is flutter clearance on a glider important?

Flutter clearance on a glider is critical because it ensures the aircraft is free from dangerous aeroelastic instabilities that can cause uncontrollable vibrations and lead to catastrophic structural failure. Flutter occurs when aerodynamic forces interact with the glider's natural structural frequencies, and without proper clearance, it can rapidly escalate beyond control. By establishing flutter clearance through ground vibration analysis and flight testing, engineers confirm that the glider can safely operate across its entire flight envelope, including at maximum permissible speeds. This process not only fulfils regulatory certification requirements but also safeguards pilot safety, protects the structural integrity of the glider, and extends its operational lifespan.



The development of Jonker Sailplanes' JS5 started in 2018 and is set to cement the company's leadership role in the development of world-class sailplanes

PROJECT IMPACT



Early Partnership:

Support for various technology development initiatives to bolster the company's reputation for technical excellence.



Initial Innovation:

Bug Wiper Device
One of the first collaborative projects was the development of a wing-based bug wiper system, replacing an expensive imported product. This innovation was critical for competitive gliding, where wing surface cleanliness affects performance.



2019/2020 Pitot-Static and Energy Control Probes:

During the 2019/20 financial year, AISI supported the development of probes for the pitot-static and total energy control systems used to measure airspeed, altitude, and flight dynamics. This project successfully substituted another imported component with

OVERVIEW OF AISI AND CSIR SUPPORT FOR JS

The AISI and CSIR have a long history with JS that has spanned a wide range of technology development and has assisted them in establishing their reputation for technical excellence.

Early Partnership

Support for various technology development initiatives to bolster the company's reputation for technical excellence.

Initial Innovation: Bug Wiper Device

- One of the first collaborative projects was the development of a wing-based bug wiper system, replacing an expensive imported product.
- This innovation was critical for competitive gliding, where wing surface cleanliness affects performance.

2019/2020: Pitot-Static and Energy Control Probes

- During the 2019/20 financial year, AISI supported the development of probes for the pitot-static and total energy control systems used to measure airspeed, altitude, and flight dynamics.
- This project successfully substituted another imported component with a locally developed solution.

2018–2022: JS5 Open Class Glider Development

- In 2018, JS began the design and development of the 24-metre wingspan Open Class JS5 sailplane.
- By early 2022, the design was completed.
- The AISI has since supported multiple phases of the JS5 project to enhance its readiness for mass production and supply to both local and international gliding markets.

These milestones reflect JS's growth as a world-class sailplane manufacturer, supported by sustained technical collaboration with AISI and CSIR.

TOWER 35

Stabilised Commander Sight Assembly Development

Tower35, a South African aerospace SMME with over two decades of specialised engineering expertise, embarked on the development of a land-based 2-axis Stabilised Commander Sight (SCS) Assembly to address a clear market gap in cost-effective, modular, and high-performance stabilised platform solutions.

The project originated from a request by a local aerospace and defence company to create a stabilised gimbal for an international client. Although that specific proposal did not materialise, it opened the door for Tower35 to conceptualise and develop its own solution. Drawing on proven building blocks and leveraging risk mitigation strategies, the company produced a demonstrator model showcased at the Africa Aerospace and Defence (AAD) Expo.

This early success formed the foundation for an AISI co-funded project to design, develop, and test an advanced demonstrator capable of meeting both local and international client needs. The project delivered significant technical and operational outcomes in less than a year, completing concept and detailed design, software development, manufacturing, system integration, and functional testing. The SCS Assembly was successfully integrated on a mast-mounted vehicle platform and demonstrated to multiple military attachés in South Africa, proving its operational viability.

This achievement demonstrated Tower35's capacity to deliver complex, high-value engineering projects within short timelines, a capability highly valued in the defence and aerospace sectors where project speed and performance are critical. By offering a system that is modular and scalable, Tower35 can tailor payload and gimbal configurations to client specifications, opening opportunities in both land and maritime surveillance applications.

The impact extends beyond technical achievement into strategic market positioning. The SCS Assembly addresses the limitations of existing market offerings, which are often prohibitively expensive and insufficiently adaptable to unique operational requirements. With its lower price point and customisable architecture, the product appeals to a broad range of defence and security clients.

Tower35 has already initiated discussions with potential international partners, including a Turkish client interested in a transfer of production model, and is exploring agreements that could lead to orders of multiple systems over the next several

years. Locally, the company is in advanced proposal stages with clients and anticipate procurement of up to 20 systems over three years for maritime use.

The project's building blocks, including high-accuracy encoders, control electronics, and standalone electro-optical payloads can be offered as independent subsystems, further diversifying revenue streams. Partnerships forged during the project, including those in technology transfer and local system integration, have positioned Tower35 as a credible OEM capable of delivering not only complete systems but also specialised components to the broader aerospace industry.

The project's success enhances South Africa's local manufacturing capability in advanced stabilised platforms, supporting national objectives for industrial growth, skills development, and technological competitiveness. With planned upgrades to payload sensors, full system qualification, and expansion into international markets, Tower35 is positioned to translate this engineering milestone into long-term commercial impact and sustainable growth.



Tower35's Stabilised Commander Sight Assembly proves that South African engineering can deliver world-class innovation within tight timelines. By combining cost-effectiveness with modular, scalable design, the system fills a critical market gap in defence and surveillance. Its successful demonstration has attracted both local and international interest, unlocking opportunities for technology transfer, partnerships, and export growth. This milestone positions Tower35 as a credible OEM driving industrial growth, skills development, and competitiveness in South Africa's aerospace sector."

PROJECT IMPACT



Technical Achievement and Capability:

Successfully designed, developed, and tested a modular, cost-effective stabilised sight system in under a year, proving South Africa's ability to deliver advanced defence technology rapidly.



Market Competitiveness:

Positioned Tower35 as a credible OEM with a scalable solution that addresses high-cost and inflexible alternatives, unlocking opportunities in both domestic and international defence markets.



Industrial Growth and Partnerships:

Strengthened local manufacturing capacity and forged technology transfer partnerships, supporting national objectives in skills development, export readiness, and aerospace sector competitiveness.

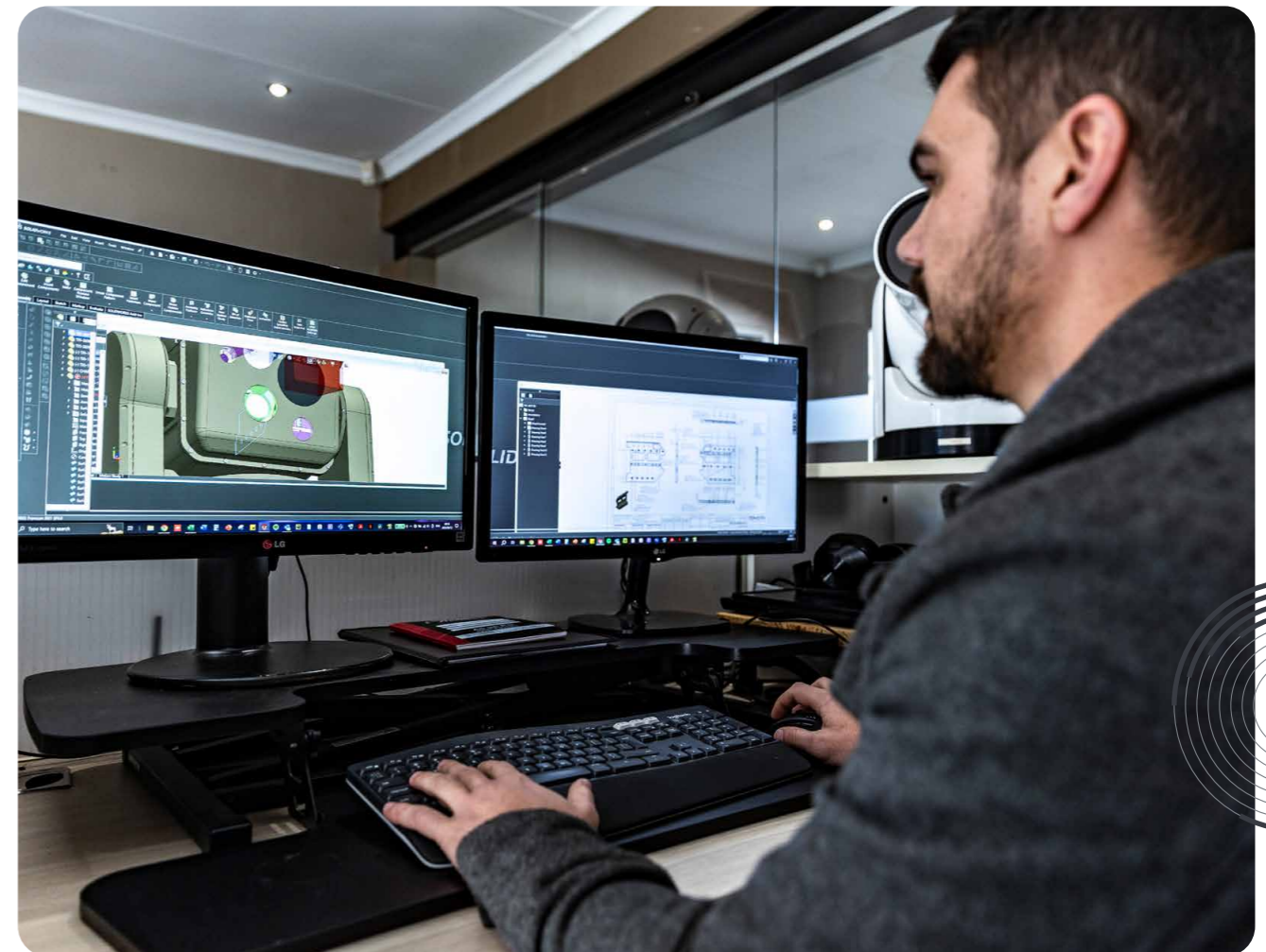

A highly skilled development and design team has played a key role in the success of the project.

DRAGONFLY AEROSPACE

CFRP Sandwich Panel Development for Satellite Primary Structures

Dragonfly Aerospace is spearheading a project to introduce Carbon Fiber Reinforced Plastic (CFRP) composite sandwich panels into South African satellite structures. Historically, lightweight composites have demonstrated substantial benefits, with past international studies achieving weight savings of up to 50% compared to metallic counterparts.

Leveraging these proven advantages, Dragonfly aims to reduce structural mass, enhance rigidity, and improve thermal stability, while eliminating the need for traditional frame-panel construction. This innovation is set to deliver tangible benefits including increased payload capacity, reduced launch costs, longer mission lifespans, and improved competitiveness for South African-built satellites in the global market.

The project's first phases brought together mechanical engineers, computer aided design (CAD) specialists, and satellite systems experts to define the technical and design requirements for the Satellite Bus Structure (SBS). Using CAD and finite element modelling, the team transitioned from aluminium to CFRP materials, conducting preliminary thermal and mechanical analyses.

Although procurement delays impacted the material characterisation schedule, the System Requirements Review was completed successfully, resolving key design discrepancies. Strategic adjustments to project sequencing now allow later-phase activities to be brought forward, keeping the overall programme on track to achieve its objectives.

Beyond technical innovation, the project has the potential to reshape South Africa's aerospace manufacturing landscape. By establishing a local supply chain capable of delivering high-value, low-volume space-rated composite structures, Dragonfly is fostering industrial capability that aligns with national priorities for advanced manufacturing and technology sovereignty.

The operational impact is equally significant. CFRP's superior stiffness-to-weight ratio will improve the survivability of satellites during launch, while its thermal stability ensures precise dimensional performance in the harsh space environment.

Ultimately, this project represents more than the development of a single satellite structure, it is a strategic investment in South Africa's space industry capability. By integrating CFRP technologies into local satellite production, Dragonfly Aerospace is positioning the country as a credible supplier of competitive, lightweight, and high-performance platforms for both domestic and international markets.

The combination of technology innovation, supplier development, and market positioning will ensure long-term impact and enable South African satellites to compete at the cutting edge of performance, cost efficiency, and sustainability in the global space economy.

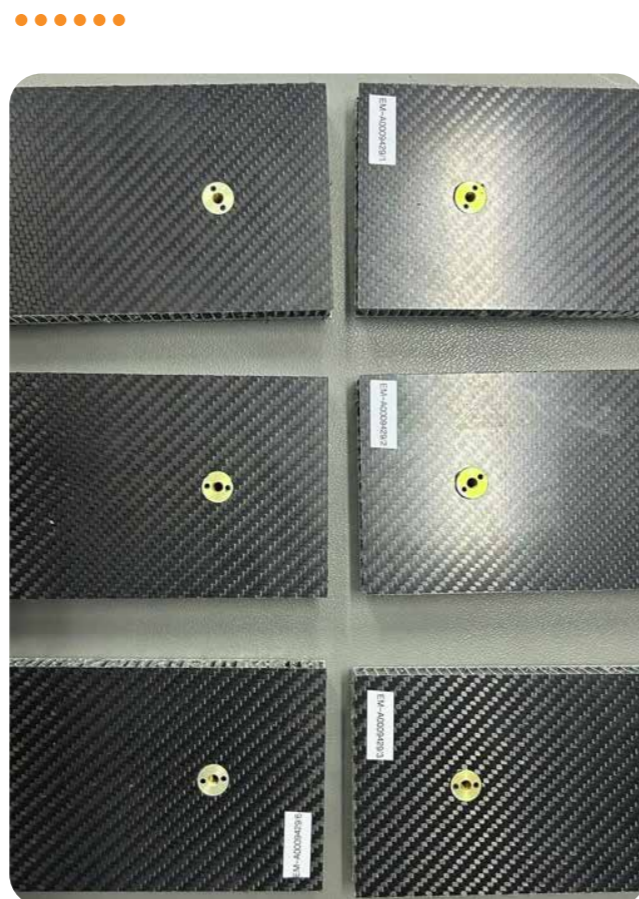

Sample used to test the in-plane shear joint with the insert three diameters distance away from the edge of the panel. The inserts were connected to a tensile machine and then an incremental displacement was applied to the sample and pulled apart until a failure occurred within the sample.

PROJECT IMPACT



Performance and Efficiency:
Enables lighter, stronger, and more thermally stable satellite structures, reducing launch costs, increasing payload capacity, and extending mission lifespans.



Industrial Capability:
Establishes a local supply chain for space-rated composites, advancing South Africa's aerospace manufacturing and technology sovereignty.



Global Competitiveness:
Positions South African-built satellites as credible, high-performance platforms in international markets through the adoption of advanced CFRP technologies.



The test sample and setup for the long beam bending test to determine the bending stresses that the panel can withstand the core ribbons directions in the transverse and longitudinal direction. The tensile machine was used to compress the panel to cause it to bend and from which we could correlate our analytical results.

ADITIV SOLUTIONS

Validation of a Locally Manufactured HYRAX Metal 3D Printer to Produce Titanium Parts for the Defence and Aerospace Industries

Aditiv Solutions is the country's only local original equipment manufacturer (OEM) of high-end metal 3D printing systems. With over 20 years of engineering experience in additive manufacturing, the company designs and produces affordable, laser-based 3D printers for industrial use. Their flagship product, the HYRAX metal 3D printer, is capable of fabricating intricate, high-strength components from advanced materials such as titanium, stainless steel, and aluminium. These machines offer significant advantages in material efficiency and energy savings, and are already in use across aerospace, automotive, mining, and defence sectors.

Aditiv Solutions undertook the validation of the HYRAX printer for serial titanium part production in highly regulated environments. The AISI supported project is focused on three core objectives: achieving long-term process reliability, enabling traceable manufacturing for certification, and ensuring safe, cost-efficient handling of titanium. Titanium's unique properties, high strength, low weight, and resistance to corrosion, make it indispensable but challenging to work with, especially under stringent aerospace and defence standards.

Through the project, Aditiv Solutions achieved key technological breakthroughs. A new control architecture was developed to support consistent, secure operation in continuous production.

“
The HYRAX metal 3D printer has been successfully validated for producing aerospace-grade titanium parts, proving South Africa's capability in advanced manufacturing”



The raw material (metal powder) utilised for the 3D printing process is housed in a series of powder kegs.

Full process traceability and reporting were implemented to meet rigorous certification requirements, and a bespoke filtration system was introduced to improve the safety and cost-efficiency of titanium powder handling. These innovations enabled the successful production of aerospace-grade titanium parts, including demonstrator components that met the client's exacting performance standards. This not only resulted in a follow-on purchase order but also created new opportunities with other subsidiaries, further validating the HYRAX platform for global applications.

The project has strengthened Aditiv Solutions' value proposition across its broader client base, including South African aerospace leaders such as Aerosud, Hensoldt Optronics, Hensoldt GEW, and Paramount.

The enhancements to the HYRAX system support higher levels of certification, operational safety, and performance. Positioned at the forefront of local innovation, Aditiv Solutions now offers a complete ecosystem, comprising hardware, engineering support, and digital manufacturing services, tailored for modern, distributed manufacturing. The project marks a pivotal milestone, elevating HYRAX from a local innovation to a globally competitive solution, and advancing South Africa's role in the high-tech manufacturing supply chain through industrial growth, technological sovereignty, and high-skilled job creation.

PROJECT IMPACT



Global Validation:
Proven capability to produce certified aerospace-grade titanium parts for defence and aviation.

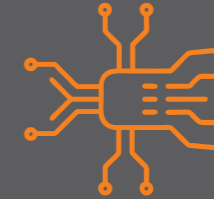

Technological Breakthroughs:
Achieved process traceability, safe titanium handling, and reliable continuous production.



Local Industrial Growth:
Strengthens SA's high-tech manufacturing, skills, and global competitiveness.

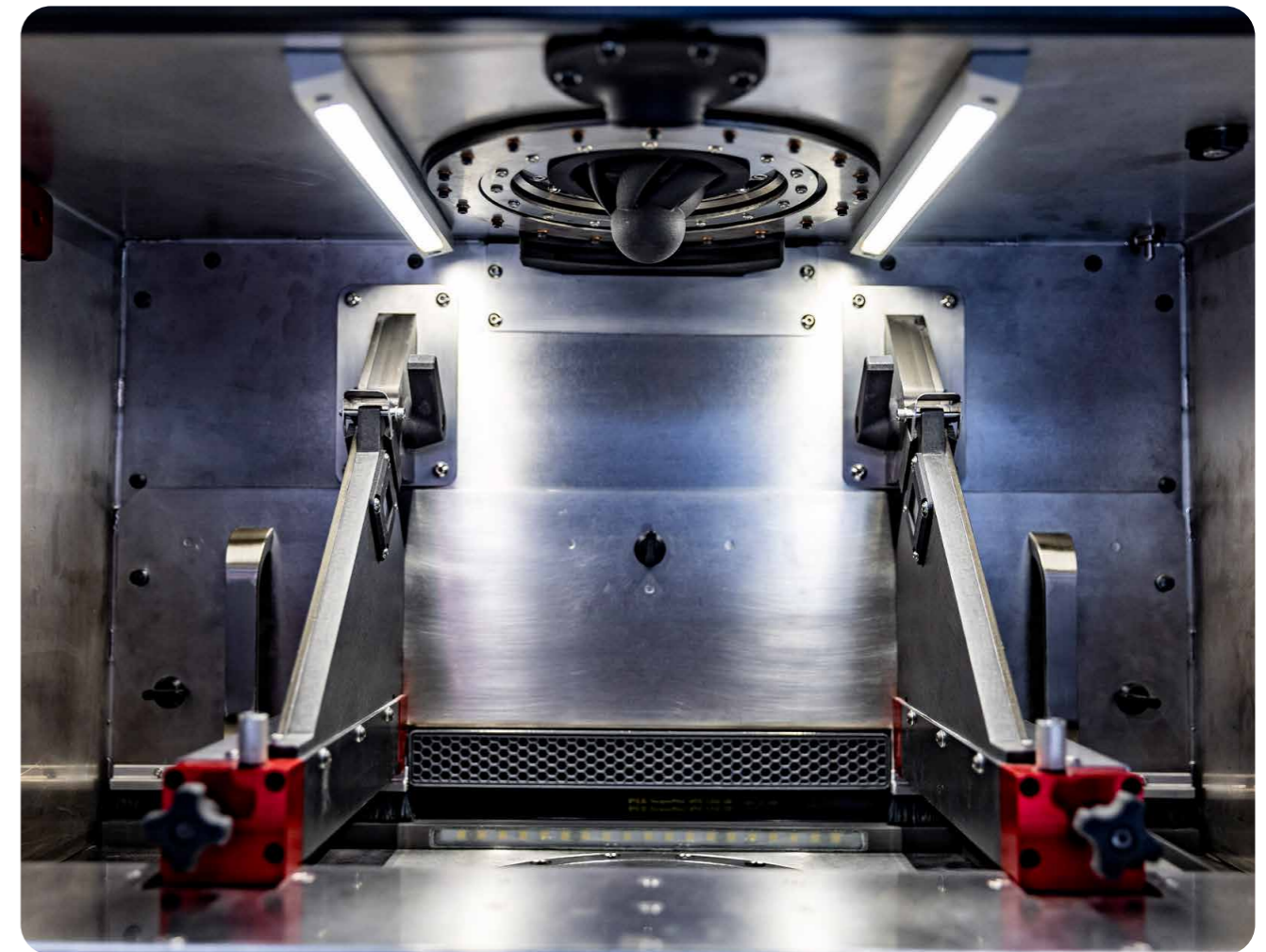

The process chamber of the HYRAX is flooded with inert gas during processing to ensure the highest quality parts.

REUTECH RADAR SYSTEMS

FMCW Short Range Radar to Detect, Locate and Track Humans

Reutech Radar Systems (RRS) has made a significant contribution to South Africa's security landscape through its longstanding expertise in integrating sensor and surveillance systems at strategic national key points and commercial sites. Having identified a gap in the local market for a low-cost, short-range radar capable of detecting and tracking humans, particularly amid rising drone threats and illegal intrusions, RRS set out to develop a flexible, locally manufactured solution. Unlike costly international systems that offer limited local support and customisation, RRS aims to deliver a fully supported, adaptable radar product tailored to diverse operational environments.

The concept for this short-range radar system originated from RRS's engineering internship programme, reflecting the company's strong commitment to skills development and innovation. Over the past three years, a group of interns transformed the idea into a working prototype with validated cost-performance viability. Building on this momentum, RRS secured support from the Aerospace Industry Support Initiative (AISI) to industrialise the radar, advance its development, and complete product qualification, taking it from a successful prototype to a commercially viable solution.

The next phase of the project will focus on refining the system for low-volume production. Enhancements include improved target classification, camera integration, and the optimisation of the Human-Machine Interface (HMI). Software and firmware updates will support a minimum viable product (MVP), while the development of a manufacturable enclosure and a comprehensive data pack will streamline production readiness. These technical improvements are crucial for real-world testing and demonstrating the radar's value proposition to potential customers in the security and safety markets.

The initiative has also generated significant economic and developmental impact. By engaging SMMEs such as RadarMarkers, TASSA, and Barracuda Holdings, RRS has promoted local content, job creation, and supply chain development. Most of the production activities have been executed within South Africa, supporting government objectives of inclusive industrial transformation. This collaborative model has

allowed for agile prototyping and cost-effective manufacturing, while simultaneously fostering long-term relationships with local suppliers. RRS has committed to maintaining these partnerships beyond the life of the project.

Human capital development has been another major outcome of the project. Through hands-on participation, interns gained expertise in RF, digital, firmware, and mechanical design, with several transitioning into permanent roles at RRS. The radar system's successful evolution from an internship concept into a market-ready technology showcases the value of structured support programmes like AISI. With improved functionality, local manufacturing readiness, and growing market interest, the FMCW SRR radar is well-positioned to serve South Africa's security needs while reinforcing national technological capability and export potential.



The genesis of this radar concept took root within the framework of the engineering intern programme at our company, a platform designed to nurture young graduates by fostering their skills and providing first-hand industry exposure. The evolution of this radar into its current prototype stage has served as the cornerstone of experiential learning within this programme."

Claude Ramasami Engineering Domain Manager Digital & RF at Reutech Radar Systems.

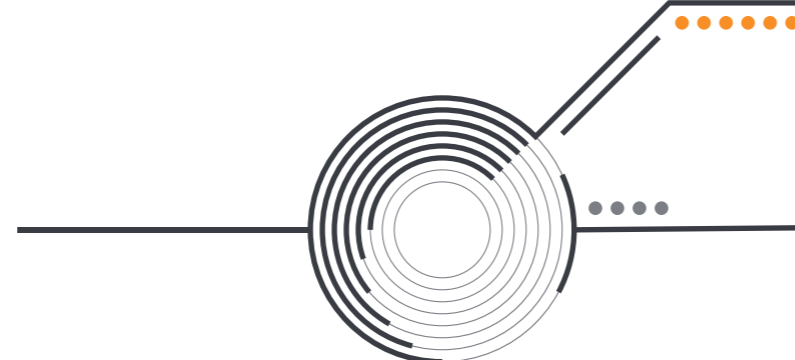

PROJECT IMPACT



Enhanced Security:

Delivers a locally manufactured, low-cost radar to counter drone threats and intrusions.



Economic Impact:

Drives SMME participation, local supply chain growth, and job creation.



Skills Development:

Transformed an internship concept into a market-ready product, upskilling young engineers.



Isaac Mpheng, Graduate Designer: RF & Microwave, taking a closer look at a solder joint for any errors and for quality control on the processor PC board on the FMCW Short Range Radar.

BRONBERG DYNAMICS

Development of a 12kg Minimum Take-off Weight (MTOW) Battery Powered UAV for Security Applications

Bronberg Dynamics, with the support of the Aerospace Industry Support Initiative (AISI), has successfully completed a groundbreaking project to develop a cost-effective, high-performance unmanned aerial vehicle (UAV) helicopter tailored to African requirements in surveillance, mapping, and precision agriculture.

Addressing the heavy reliance on costly imported UAVs, the project resulted in the design and manufacture of a modular, lightweight, coaxial rotor UAV with vertical take-off and landing (VTOL) capabilities. This locally developed solution delivers exceptional performance at a competitive cost, proving that South African innovation can match and even exceed global standards in UAV technology.

What sets this UAV apart is its focus on solving context-specific challenges. Designed for extended flight endurance, compact deployability, low acoustic signature, and modular payload capacity, the platform was shaped through close consultation with both military and civilian stakeholders. These design priorities translated into an impressive flight time of over 90 minutes, well beyond the original 60-minute target, achieved through efficient power management and a custom-built flight controller. The result

is a UAV platform that is not only technologically advanced but also highly practical for diverse African operational environments.

The project delivered significant technological advancements. Features such as interchangeable payload mounts, real-time telemetry, a microSD-based data logging system, and control algorithm tuning highlight the system's flexibility and performance. Its robust, modular design enables swift payload swaps between optical and thermal sensors, while the aircraft can be deployed in under 10 minutes, ideal for rapid response scenarios. The UAV also demonstrated reliable performance in gusty conditions, showcasing its field-readiness and stability in demanding use cases.

On an organisational level, the project marked a strategic leap forward for Bronberg Dynamics. Developing an in-house flight controller reduced dependency on foreign systems and expanded the company's internal technical capacity. Local prototyping and partnerships with domestic manufacturing firms helped validate an efficient, end-to-end product development process. These achievements not only strengthened Bronberg's innovation pipeline but also laid the groundwork for future UAV iterations tailored for broader market applications.

The broader socio-economic and industrial impacts are equally notable. The project supports industrial competitiveness, import substitution, and localisation within the aerospace sector. It enabled job creation and practical training for engineering students and young professionals, building a skilled pipeline of aerospace talent. The project aligns with AISI's mandate to support sovereign capability, local innovation, and industrialisation, setting a powerful example of how strategic public-private collaboration can generate commercially viable, transformative outcomes for South Africa's high-tech manufacturing landscape.

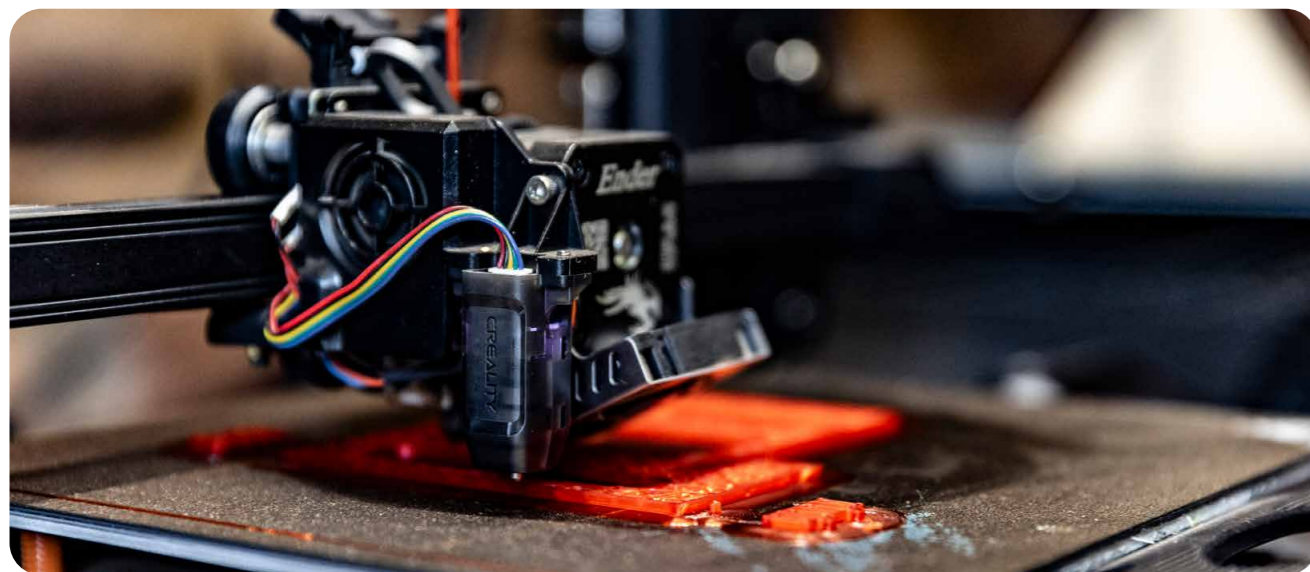

Leading technology was utilised during all development phases

PROJECT IMPACT



Affordable Innovation:
Delivered a locally designed UAV helicopter that reduces reliance on costly imports.

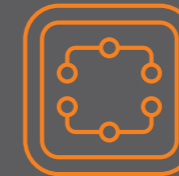

Context-specific Performance:
Achieved extended endurance, modular payloads, and rapid deployability for African needs.



Local Industrial Growth:
Strengthened SA aerospace capacity, jobs, and skills through in-house development and partnerships.

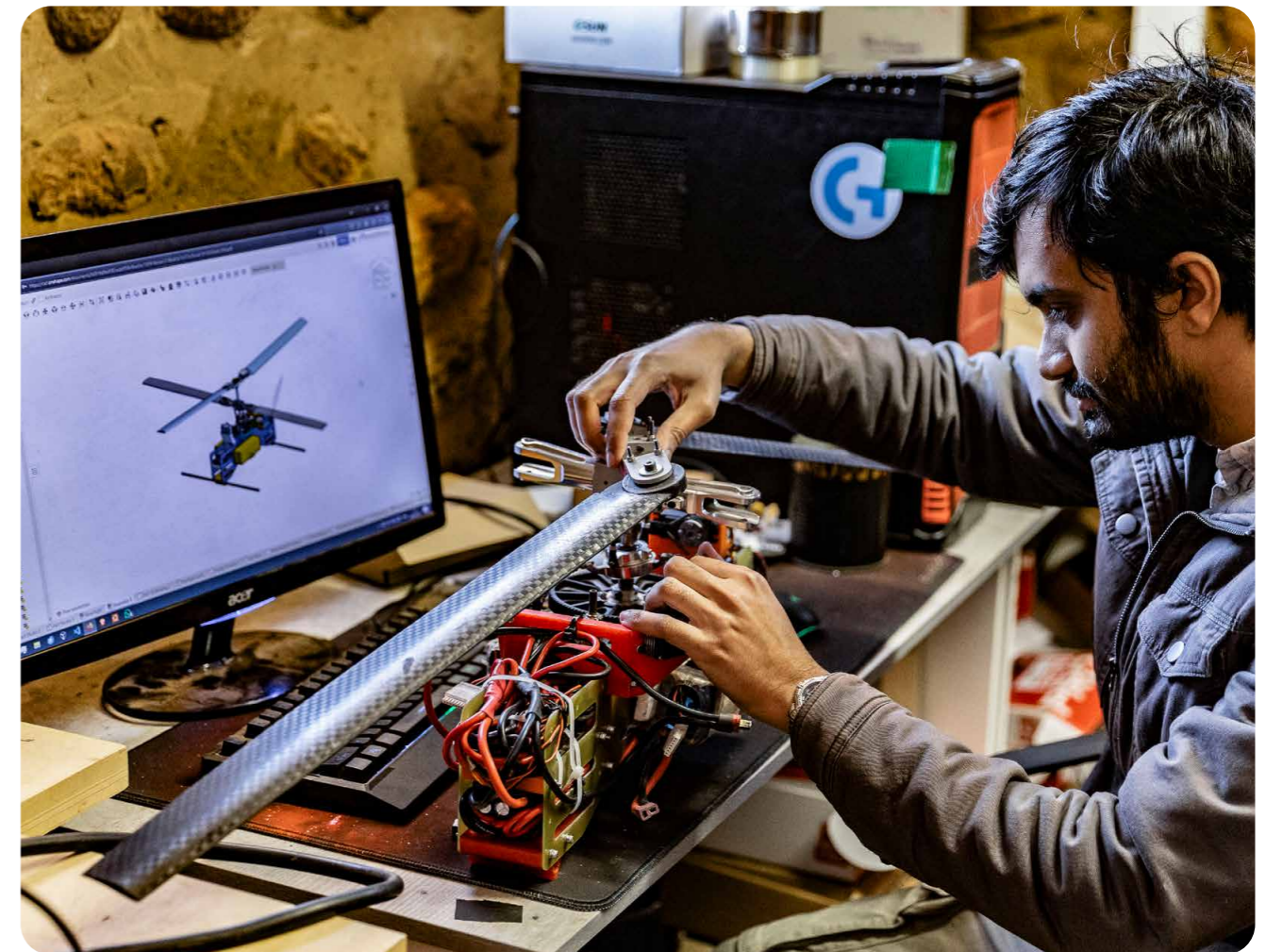

The development of the prototype has required high level engineering and design skills, combined with rigorous testing

NABLATEQ

Development of a VGA/XVGA Long Wave Infrared Thermal Imaging Core for Surveillance and Monitoring

For years, the local unmanned aerial vehicle (UAV) and landward platform industries have been constrained by the reliance on imported gimballed sensor payloads, which are not only expensive and difficult to source, but also subject to restrictive export controls. These limitations have created significant barriers to entry for domestic manufacturers, curbing their ability to compete in both local and international markets.

Nablateq, a South African technology innovator specialising in advanced imaging systems, with support from the AISI, is intent on addressing the country's ability to design and manufacture high-performance thermal imaging solutions. Nablateq's approach, that combines imported detector components with locally designed electronic hardware and precision-engineered mechanical structures, seeks to develop world-class imaging systems that are fully aligned with South Africa's localisation and industrial growth objectives.

The "Proton" Thermal Imaging Core for Surveillance and Monitoring project responds directly to a rising global demand for Intelligence, Surveillance, and Reconnaissance (ISR) capabilities. This demand is driven by geopolitical tensions and the rapid adoption of UAV technology across defence, security, agriculture, and industrial inspection sectors.

Proton offers a compact, lightweight, and power-efficient thermal imaging core with advanced performance that meets stringent international standards. Its embedded image processing and deep neural network capabilities reduce the Cost, Size, Weight, and Power (C-SWAP) parameters compared to legacy systems, giving local manufacturers the ability to compete in markets across Africa and beyond.

The competitive edge of the Proton core lies in its integrated, modular design that supports rapid adaptation for different applications, from UAV gimbals to vehicle-mounted situational awareness systems. This flexibility ensures that the product can be tailored to specific customer needs while maintaining exceptional performance. Partnerships with established defence and technology players, such as Paramount Group and Bronberg Dynamics, underline strong market confidence and present opportunities for both domestic deployment and international expansion.

Strategically, this project strengthens South Africa's expertise in high-performance infrared imaging while stimulating skills development across the aerospace and defence value chain. Nablateq is involving SMMEs and technical specialists in design, manufacturing, and integration, fostering niche capabilities and building a resilient local supply chain. This aligns with national objectives to reduce dependence on foreign technology, boost manufacturing competitiveness, and grow export-ready industrial sectors.

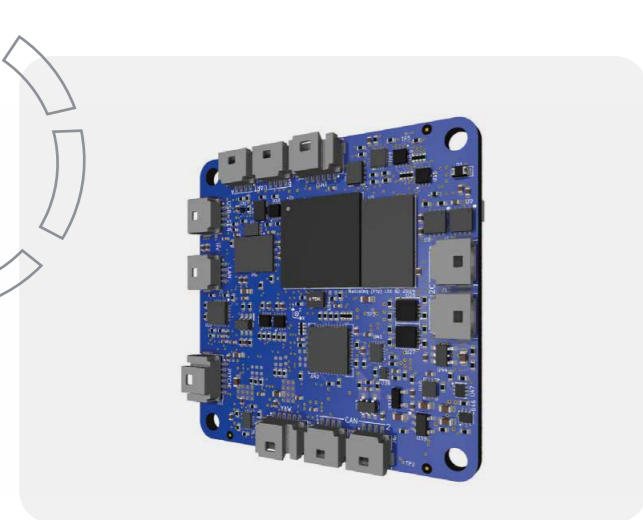

Nablateq's proprietary gimbal control processor (GCP) – a 16-layer printed circuit board responsible for gimbal stabilisation and camera frame synchronisation. It features an on-board GPS module, ethernet, CAN-bus and many auxiliary ports for integration flexibility.

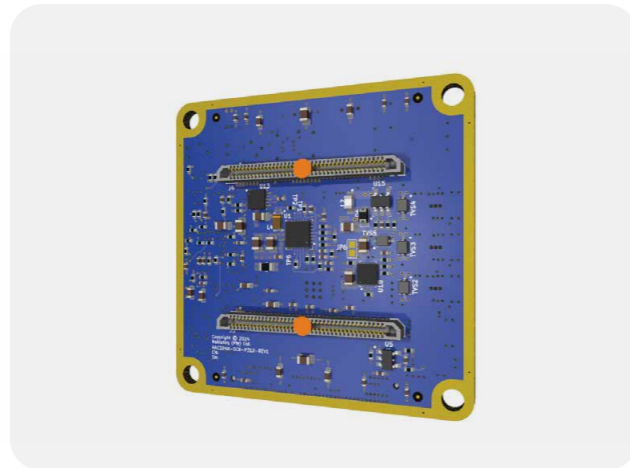

Nablateq's sensor carrier board for infrared cameras. This board facilitates communication between the infrared detector and the image processor; and drives the infrared detector's thermoelectric cooler.

PROJECT IMPACT



Localisation and Competitiveness:

Reduces reliance on imported gimballed sensor payloads by developing advanced, locally engineered thermal imaging solutions that meet international standards.



Market Expansion:

Positions South African UAV and landward platform industries to access growing global ISR markets with a compact, modular, and power-efficient product.



Skills and Supply Chain Development:

Stimulates specialised skills, SMME participation, and a resilient local supply chain, aligning with national industrial growth and export objectives.

"The Proton project is progressing well, with laboratory integration of key hardware modules already underway and prototype delivery scheduled for early 2024," emphasises Gert Erasmus from Nablateq. "This initiative showcases how South African innovation and collaborative engineering can deliver world-class ISR technology, open new market opportunities, and strengthen our position as a competitive player on the global stage."

"Nablateq's approach combines imported detector components with locally designed electronic hardware and precision-engineered mechanical structures."

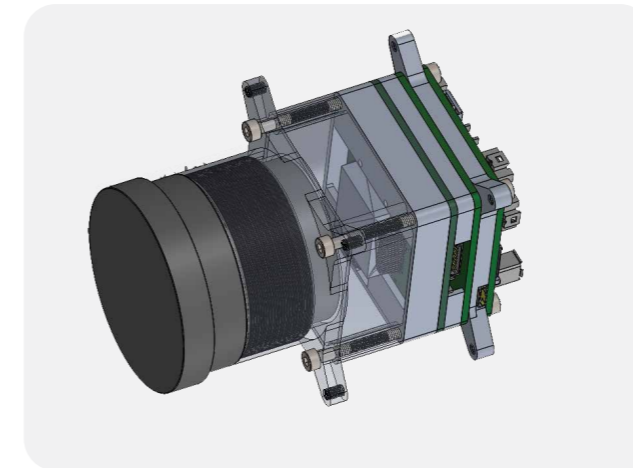

A model of a complete sensor stack for one of our clients. The camera lens and aluminium frame can be seen in grey, and the assembled circuit boards (detector, carrier board and image processor) can be seen in green.

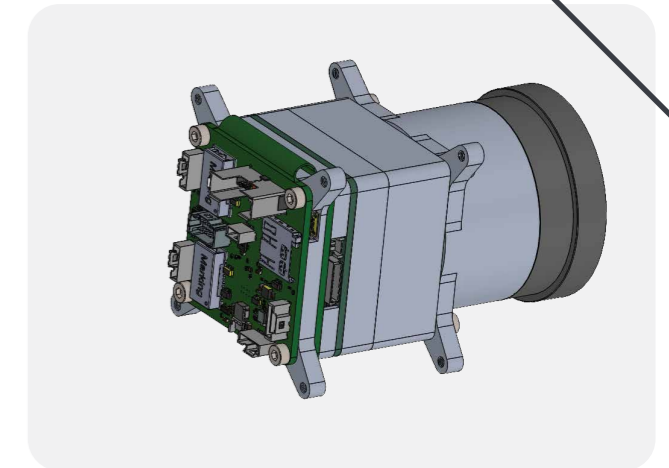

A fully assembled K130 gimbal, of which we have manufactured 4, thus far. It is a complete and marketable product which has seen interest from both local and international clients.

ETION CREATE

Etion Autotracker Enhancement Development

The development of ETION Create's Autotracker, with support from the AISI, represents a significant step towards building South Africa's independent capabilities in advanced video tracking technology. Initially conceived as a solution that could run on small, embedded platforms or Linux-based systems without reliance on International Traffic in Arms Regulations (ITAR) controlled technology, the Autotracker was successfully developed within budget and timelines.

Its core advantage lies in being a standalone solution, free from the need for extensive proprietary video system integration, offering a commercially viable alternative to expensive foreign-sourced products. This achievement sets the stage for further enhancements aimed at making the Autotracker even more competitive in the global market.

The next phase of development focused on integrating advanced functionalities such as multi-target tracking, object tracking, and an overwatch capability incorporating object detection, identification, and difference detection. These improvements enabled the Autotracker to perform more complex and precise surveillance and targeting tasks, increasing its appeal for both defence and commercial applications.

“*ETION Create's Autotracker marks a major step in South Africa's journey toward independent video tracking technology. Developed without ITAR restrictions, it delivers a cost-effective alternative to foreign systems while enabling advanced multi-target tracking and object detection. Its compact, embedded design allows seamless integration into electro-optical sights, expanding applications across defence and commercial sectors. By fostering collaboration with local SMMEs like Tower35, the project strengthens self-reliance, industrial growth, and technological competitiveness in the aerospace and defence industries.*”

A key innovation is the ability to embed the tracking function directly into small form factor electro-optical sights, removing the need for external modules. This will allow for more compact, efficient systems suitable for a variety of platforms, including those used in high-mobility or space-constrained operational environments.

Collaboration with local SMMEs forms a central pillar of this project's impact. Tower35, a specialist in electro-optical sight design and development, has been identified as a strategic partner to integrate the enhanced Autotracker into its products. This partnership will see Tower35 adapt existing hardware to accommodate the new embedded tracking module, creating a fully integrated sighting system with advanced targeting capabilities.

The broader implications of the project extend beyond technical innovation. By offering a locally developed, platform-independent autotracker, ETION Create addresses a long-standing challenge faced by South African companies, being the dependence on costly foreign solutions with restrictive licensing models.

The ability to provide clients with technology that is fully owned, controlled, and adaptable to their specific needs supports greater self-reliance, promotes industrial growth, and empowers other local manufacturers to integrate cutting-edge capabilities into their own products.

Ultimately, the enhanced Autotracker project is a demonstration of how targeted innovation funding, skilled engineering, and strategic industry collaboration can deliver tangible results for South Africa's aerospace and defence sectors.



PROJECT IMPACT



Technological Independence:

Developed a locally owned, ITAR-free video tracking solution that reduces reliance on costly, restricted foreign technologies.



Innovation and Competitiveness:

Delivered an embedded, small form factor system with advanced multi-target tracking and object detection, creating globally competitive surveillance and targeting capabilities.



Industrial Growth and Collaboration:

Strengthened local industry through partnerships fostering self-reliance, skills transfer, and integration of advanced technologies into South African defence and commercial products.



Testing of moving targets in a public area



The CheetahNav Smart Display Unit demonstrating its ability to track a moving target



Leon Theunissen and Phenylo Mongale are seen here testing the system created with the AISI support

HH INDUSTRIES

Design and Integration of Additively Manufactured Turbojet Engine Components for Enhanced Performance and Local Production Capability

Manufacturers of small turbojet engines have long relied on imported components, a dependency that brings high costs, extended lead times, and exposure to supply chain disruptions. Recognising the need for greater technological independence and enhanced operational performance, HH Industries set out to design and integrate additive manufactured parts that meet international quality standards while delivering performance gains through lighter, more efficient designs tailored to local requirements.

HH Industries, a leader in advanced metal additive manufacturing, spearheaded the development of locally produced, high-performance turbojet engine components to address critical supply chain, cost, and performance challenges in South Africa's aerospace sector.

Using laser powder bed fusion additive manufacturing, HH Industries successfully produced high-value components such as fuel injectors, turbine stators, fuel manifolds, and turbine housings within South Africa. This localised approach has reduced dependence on foreign suppliers, cut logistical and production costs, and lowered the environmental impact of overseas shipping. At the same time, delivering lighter, more fuel-efficient parts that enhance engine performance, a crucial advantage in both domestic and export markets.

Beyond technical achievements, the project has significantly strengthened local industrial capacity and built a sustainable skills pipeline. HH Industries hosted and upskilled interns as additive manufacturing operators, ensuring that young engineers gained hands-on experience in specialised, high-demand fields.

The strategic impact of localising aerospace component production is substantial. By manufacturing these precision parts domestically, HH Industries has secured critical supply lines, shortened turnaround times, and enabled the customisation of components to meet unique operational needs. In aerospace applications, where precision, reliability, and adaptability are essential, the ability to tailor components while using high-performance aluminium and nickel-based alloys places South African manufacturers on par with global leaders.

Looking ahead, the project's success opens the door to wider innovation and R&D opportunities. The proven capability to design, manufacture, and integrate additive manufactured turbojet components locally positions South Africa to explore applications in UAV propulsion, space systems, and next-generation aviation technologies. This diversification strengthens the resilience of the aerospace sector while expanding its commercial reach.

This project has delivered immediate operational benefits and lasting strategic value. It demonstrates how local innovation, skills development, and production localisation can intersect to enhance competitiveness, drive sustainability, and position South Africa as a credible player in the global aerospace supply chain.



Additively Manufactured AlSi10Mg fuel manifolds evaluated for quality after post-processing comparing the two different designs for additive manufacturing (DfAM) iterations.

PROJECT IMPACT



Localisation and Resilience:

Reduced reliance on imported turbojet components by producing high-performance parts domestically, cutting costs, lead times, and supply chain risks.



Performance and Sustainability:

Delivered lighter, more fuel-efficient components using advanced additive manufacturing, enhancing engine performance while lowering environmental impact.



Skills and Industrial Growth:

Upskilled young engineers in specialised additive manufacturing, building local expertise and strengthening South Africa's aerospace industrial capacity.

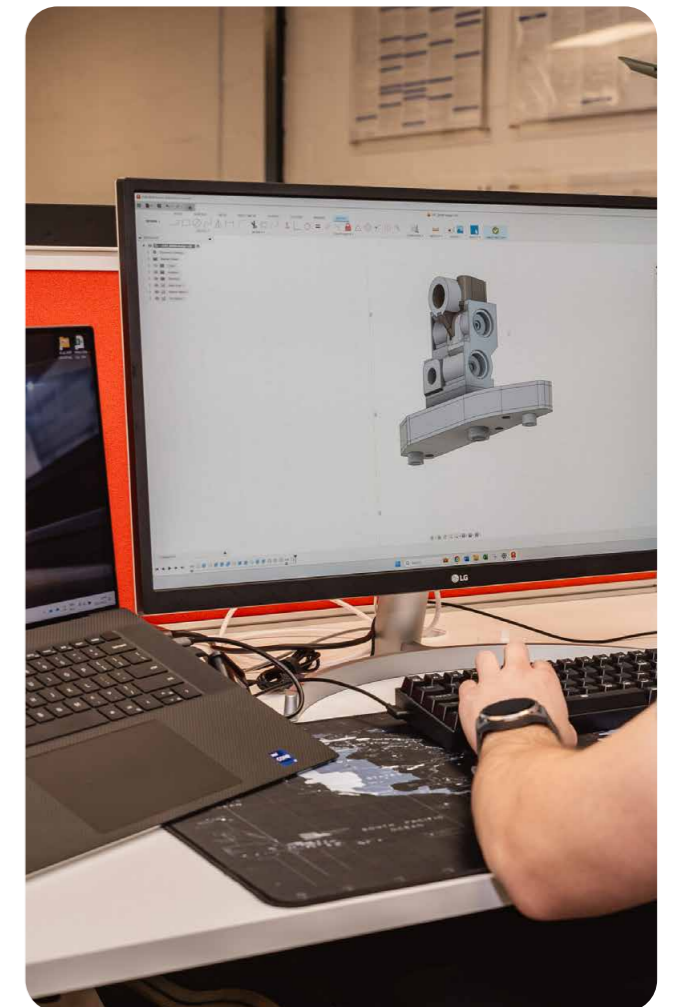

The project's rigorous design, prototyping, and optimisation phases produced repeatable, high-quality results while nurturing a new generation of talent in advanced manufacturing

SPARCX

Radar Target Classification

The Border Management Authority (BMA) Act provides the policy foundation for strengthening South Africa's border control capabilities, placing technology at the centre of national security.

Radar systems, with their 360-degree coverage, ability to operate in almost any weather, and capacity to track thousands of objects in real time, are indispensable for this task. Yet, achieving true independence and competitiveness in radar technology requires locally designed solutions that are cost-effective, scalable, and adaptable to African conditions.

This is the gap that SPARCX, a 100% black military veteran-owned enterprise, is addressing with its Radar Target Classification (RTC) project.

The project's importance lies in its ability to tackle one of radar's greatest challenges: distinguishing between different targets in highly complex and noisy environments. Conventional classification methods often fall short when exposed to variables like frequency, polarisation, and aspect angle. By advancing intelligent classification algorithms that are resilient to noise and capable of rapid, real-time decision-making, SPARCX is laying the groundwork for systems that are both technically advanced and operationally viable. Such innovation not only strengthens border management and defence, but also opens avenues for dual-use applications in civilian markets, from traffic monitoring to disaster management.

Beyond technical innovation, the impact of the RTC project is strategic. South Africa currently imports a significant proportion of its radar solutions, which are expensive and often tied to restrictive licensing. By developing home-grown capabilities, SPARCX is reducing reliance on foreign technology, enabling import replacement, and creating opportunities for export into new territories. The project also supports industrialisation, localisation, and skills development, all of which align with national priorities for reindustrialisation and sovereign capability. Partnerships with organisations like Reutech Radar Systems have amplified these benefits, strengthening the local defence ecosystem.

Progress has already been impressive. SPARCX has leveraged the Low-Cost Radar (LCR) system at Technology Readiness Level 5 as a data source for classification. Training provided by senior engineers at Reutech has enhanced the team's capacity to engage with radar data processing, Doppler analysis, and data labelling methodologies. Building on this foundation, SPARCX

conducted an extensive review of leading algorithms, including Neural Networks, Random Forests, Support Vector Machines, and XGBoost, before optimising an enhanced XGBoost model as the core of its classification system.

This work has moved from concept to demonstrator stage, with PC-based prototypes and Qualcomm NPU implementations already tested. The architecture now includes modular components such as radar system interfaces, preprocessing modules, inference engines, and post-processing display functions. These advances have enabled the development of a multi-platform RTC solution that supports centralised model training but can be deployed flexibly across CPUs, DSPs, NPUs, and FPGAs. This modularity ensures the system is not only effective but also adaptable to a wide range of defence and civilian platforms.

Looking ahead, the project is positioned to deliver even greater returns. The integration of refined algorithms into a cohesive, PC-based classifier design marks the completion of Phase 1 and sets the stage for expanded deployment in real operational environments. With continued support from the Aerospace Industry Support Initiative (AISI) and partnerships with local industry, SPARCX is well on its way to transforming South Africa's radar landscape. The RTC project is more than an engineering milestone, it is a demonstration of how targeted innovation, skills development, and collaboration can generate high-impact outcomes for national security, industrial growth, and global competitiveness.



What is Radar Target Classification?

Radar target classification is the process of analysing radar signals reflected from objects to determine their type, identity, or category, such as distinguishing between aircraft, ships, vehicles, or natural clutter like birds and weather. This is achieved by evaluating features such as the target's size, shape, motion patterns, radar cross-section (RCS), and frequency responses. Advanced methods use signal processing, pattern recognition, and increasingly machine learning or artificial intelligence algorithms to classify targets more accurately and in real time. Effective radar target classification is essential for enhancing situational awareness, reducing false alarms, and supporting decision-making in both defence and civilian applications such as air traffic control, maritime monitoring, and surveillance.

PROJECT IMPACT



Strengthening Sovereignty and Security:

Reduces reliance on costly imported radar systems by developing a locally owned, noise-resistant classification solution that enhances border management and defence capabilities.



Industrial Growth and Skills Development:

Creates jobs, builds engineering capacity, and trains young professionals in advanced radar and electronic warfare technologies, supporting South Africa's high-tech industrialisation agenda.



Export and Dual-Use Potential:

Opens opportunities for international markets and spinoff applications in civilian sectors such as traffic monitoring, disaster management, and infrastructure security.

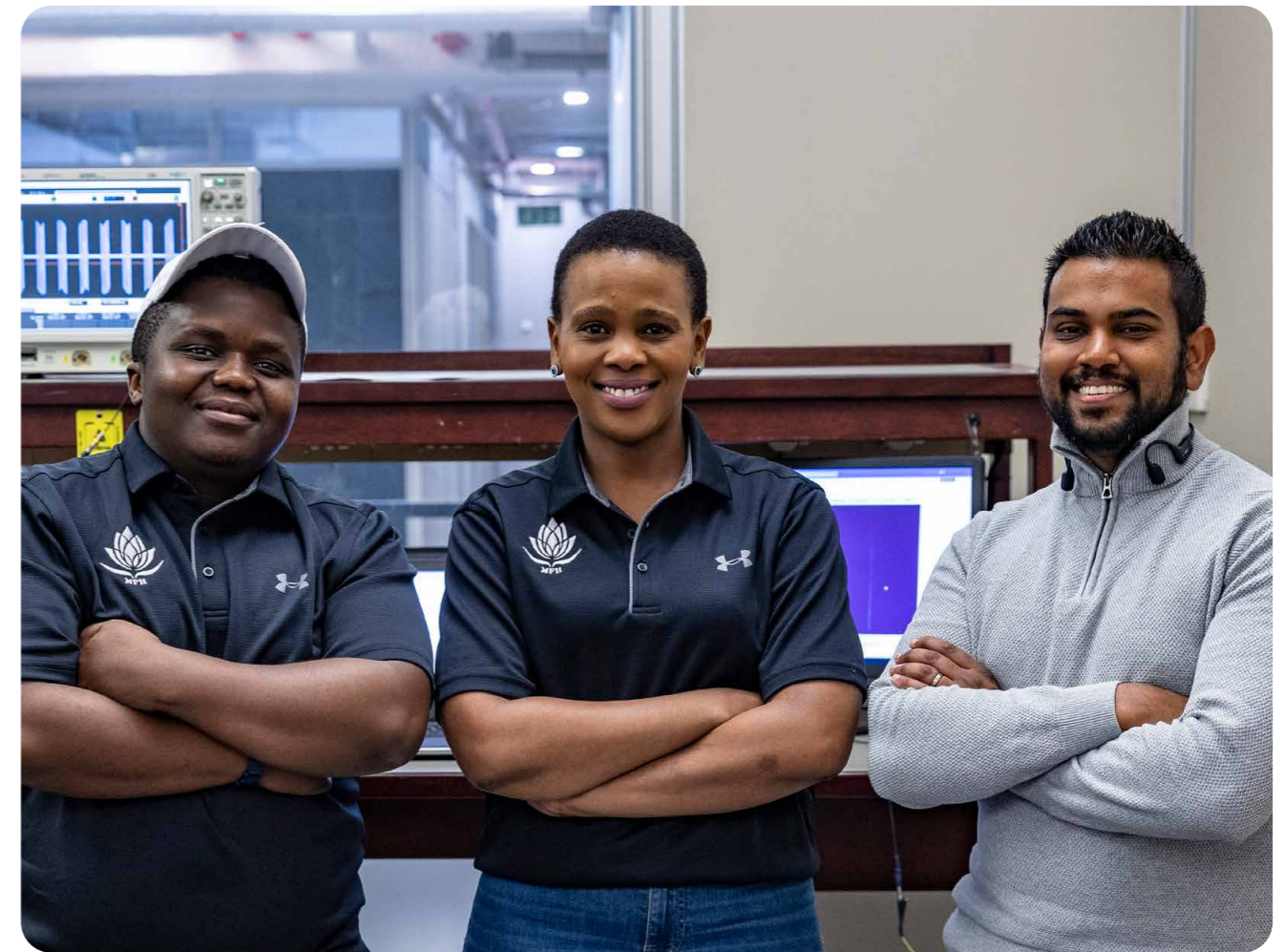

Seen here from left to right are: Moorosi Motahe – Lead Design Engineer, Octavia Mdluli – Project Manager, and Reeshen Reddy – Research Group Leader: Digital Electronic Warfare

LAMBDA G

Global Navigation Satellite System (GNSS) Antenna Development

South Africa has a proud history in the space industry, with both government and private enterprises contributing to space engineering and mission support over the decades. Today, this tradition is being advanced in exciting new ways through the growth of “New Space” activities, which emphasise smaller, cost-effective satellites rather than the large and expensive spacecraft of the past. These new missions demand lightweight, energy-efficient, and affordable components, an area where South African innovators like LambdaG are now making their mark. Their work is helping position the country as a global competitor in the rapidly expanding market for small satellite technology.

LambdaG’s flagship initiative is the development of a space-qualified Global Navigation Satellite System (GNSS) antenna for spacecraft operating in Low Earth Orbit (LEO). These antennas are crucial because they provide navigation and timing data that ensure satellites can operate effectively in orbit. The company has designed both a single-band system, which complements existing GPS technology, and a wideband system capable of receiving all GNSS frequencies from L1 to L5. The wideband design incorporates a High Impedance Surface (HIS), an advanced metamaterial that improves performance by eliminating surface wave losses and reflecting electromagnetic waves without distortion. This innovation could significantly boost the competitiveness of locally produced antennas in international markets.

The project’s impact extends well beyond the technology itself. It has already created new employment opportunities and has nurtured advanced skills development within the company. For example, intern Patsa Khotso joined LambdaG and commenced doctoral research into compact antenna design using high impedance surfaces for small satellites. This not only enhances South Africa’s scarce skills base in advanced engineering but also builds a pipeline of specialised expertise for the country’s aerospace future.

Strategic collaboration has been key to the project’s success. LambdaG is working with several SMMEs including, Simutron, Opti-Num Solutions, PCBway, The Elite Group, METAL HEART,

CHG Engineering CC, and ICAPE TRAX, ensuring that the benefits of the programme ripple across the local manufacturing and technology ecosystem. Academic support from the University of Pretoria and partnerships with the South African National Space Agency (SANSA), NewSpace Systems, Aeronet of Things, and Qfinsoft have further strengthened the initiative. Together, these collaborations highlight how government, academia, and industry can align to drive innovation in priority sectors.

Importantly, the project contributes directly to South Africa’s national strategies and programmes by replacing imported products with locally manufactured alternatives. It enhances industrial competitiveness, broadens export capability, and creates pathways for SMMEs to enter high-value global supply chains. By leveraging additive manufacturing (AM) to produce traditional waveguide antenna assemblies and mounting hardware, LambdaG is not only addressing domestic needs but also positioning itself as a supplier of advanced, lightweight antenna systems for international spacecraft and defence markets.

Looking ahead, LambdaG expects to reach the manufacturing stage by the first quarter of 2026, an important milestone in bringing its innovations to market. As Dr Vernon Davids, CEO of LambdaG, notes, this project exemplifies how small enterprises can transform South Africa’s role in the global aerospace industry: by delivering high-value, high-performance communication components that meet international demand while building local capacity and creating jobs. It is a vivid example of how “New Space” is not just about technology, but also about unlocking skills, opportunities, and industrial competitiveness for the nation.



GNSS antenna dielectric material undergoing magnetic evaluation at SANSA’s tri-axial Helmholtz Coil.

PROJECT IMPACT



Advancing Local Aerospace Innovation:
Development of a space-qualified GNSS antenna with cutting-edge wideband and High Impedance Surface (HIS) technology positions South Africa as a global competitor in the small satellite market while reducing reliance on imports.



Driving Skills and Job Creation:
The project has created youth and black employment opportunities, supported advanced skills development, and enabled doctoral-level research in compact antenna design, strengthening South Africa’s scarce engineering expertise.



Strengthening Industrial Competitiveness:
By leveraging additive manufacturing and collaborating with SMMEs, academia, and SANSA, the project enhances local supply chains, creates export potential, and boosts South Africa’s participation in global aerospace and defence markets.



Patsa Khotso (Left) joined LambdaG as Antenna and RF Engineer. He is also commencing a DEng degree with a topic related to high gain antennas for Small Satellites. He is seen here with Dr Vernon Davids who has played a key role in the design of the GNSS antenna.



AEROSPACE AND DEFENCE

STANDARDS AND ACCREDITATION

.....
Standards and accreditation are critical in South Africa as they ensure that products, services, and systems meet consistent, internationally recognised benchmarks for quality, safety, and performance. In a globalised economy, compliance with standards allows South African industries to compete internationally, attract investment, and integrate into global value chains.

Accreditation supports regulatory compliance, promotes operational efficiency, and reduces risks by validating that businesses, laboratories, and certification bodies are competent and credible. It also drives innovation and industrial growth by encouraging continuous improvement and alignment with emerging technologies and best practices.

For South Africa's transformation and localisation objectives, standards and accreditation help level the playing field for SMMEs, enabling them to meet procurement requirements and participate in high-value sectors such as manufacturing, energy, aerospace, and the marine industry.



TECHNOLOGY BASED SUPPLIER DEVELOPMENT - STANDARDS AND ACCREDITATION

Shrike Marine : ISO 9001:2015
Luvhone Engineering: ISO9001 and ISO14001
Petrawell: Provision of Consulting Services to Implement ISO 9001:2015 QMS

ABOUT THE INTERNATIONAL ORGANISATION FOR STANDARDIZATION

The International Organization for Standardization (ISO) is an independent, non-governmental body established in 1947 and headquartered in Geneva, Switzerland. With over 170 national standards bodies as members, including the South African Bureau of Standards (SABS), ISO plays a pivotal role in setting voluntary, consensus-based international standards. These standards serve as benchmarks for quality, safety, and consistency across nations and industries.

ISO develops standards that are essential for ensuring quality, safety, efficiency, interoperability, and sustainability across a wide range of sectors. By defining clear requirements and best practices, ISO standards help organisations streamline operations, improve service delivery, and ensure compatibility and reliability of systems and products on a global scale.

The adoption of ISO standards provides numerous strategic benefits. They improve operational efficiency, enhance performance, and build customer and stakeholder confidence by demonstrating a commitment to quality and safety. ISO standards also help reduce risks and liabilities, support regulatory compliance, and open access to international markets by aligning products and services with global expectations. Based on the benefits mentioned above, AISI provides ISO implementation and certification support to SMME beneficiaries.

While ISO itself does not certify companies, it provides the framework for certification, which is carried out by accredited third-party bodies.

STANDARD ISO DEVELOPMENT PROCESS

AISI generally follows a 10-step process for ISO standards implementation and certification.

PHASE 1:

Gap analysis and Assessment of the existing internal systems and documentation

PHASE 2:

Basic awareness training for all staff

PHASE 3:

Development of manuals

PHASE 4:

Implementation of the ISO documentation

PHASE 5:

Baseline risk assessment

PHASE 6:

Internal auditor training

PHASE 7:

Internal audit

PHASE 8:

Clearance of internal audit findings and sustainable continual improvement

PHASE 9:

Preparation for certification including management review

PHASE 10:

Certification



ISO 9001

ISO 9001 is a globally recognised standard for quality management. It helps organisations of all sizes and sectors to improve their performance, meet customer expectations and demonstrate their commitment to quality. Its requirements define how to establish, implement, maintain, and continually improve a quality management system (QMS).

Implementing ISO 9001 means an organisation has put in place effective processes and trained staff to deliver flawless products or services time after time. ISO 9001 is the most widely used quality management standard in the world and defines seven quality management principles including a strong customer focus and continual improvement.

Business benefits include customer confidence, effective complaint resolution, process improvement, and ongoing optimisation. Regular audits and reviews encouraged by ISO 9001 enables organisations to continually refine their quality management systems, stay competitive, and achieve long-term success.



ISO 14001

ISO 14001 is the internationally recognised standard for environmental management systems (EMS). It provides a framework for organisations to design and implement an EMS and continually improve their environmental performance. By adhering to this standard, organisations can ensure they are taking proactive measures to minimise their environmental footprint, comply with relevant legal requirements, and achieve their environmental objectives.

The framework encompasses various aspects, from resource usage and waste management to monitoring environmental performance and involving stakeholders in environmental commitments. In an age of heightened environmental consciousness and increasing global challenges such as climate change, biodiversity loss, and resource depletion, organisations have a pivotal role to play. ISO 14001 offers a structured approach for businesses to address these pressing concerns.

By adopting this standard, organisations signal a commitment not only to regulatory compliance but also to ongoing environmental improvement. This proactive approach to environmental management can result in tangible benefits, such as reduced waste, energy conservation, and cost savings. Furthermore, it enhances an organisation's reputation, fosters stakeholder trust, and often constitutes a critical step for engaging in global trade and supply chains. Simply put, ISO 14001 stands as a testament to an organisation's dedication to a sustainable future, blending environmental responsibility with strategic business growth.



ISO 45001

ISO 45001 is the international standard for occupational health and safety management systems, providing a structured framework for organisations to identify, control, and reduce workplace health and safety risks while ensuring compliance with relevant legislation. It emphasises proactive hazard identification, risk assessment, employee participation, and continuous improvement through monitoring, audits, and reviews. The standard can be integrated with other management systems such as ISO 9001 (quality) and ISO 14001 (environment), aiming to reduce work-related injuries, illnesses, and fatalities, foster a strong safety culture, and create safer, healthier working environments.

SHRIKE MARINE

Founded in 2005 and headquartered in Cape Town, Western Cape, Shrike Marine is a privately owned SME that operates at the forefront of the defence, marine, aviation, and commercial sectors, delivering specialised electronic hardware solutions and cable harness manufacturing tailored to mission-critical environments.

Its product portfolio includes advanced systems such as missile safety mechanisms, unmanned aerial vehicles (UAV) and vehicle power management units, submarine display consoles, automated cable testers, depot-level chargers, and power distribution units, each engineered to meet stringent military specifications and operational requirements.



Shrike Marine's capabilities extend from rapid prototyping and in-house qualification testing to scalable full-scale production, all underpinned by its dedicated research and development facilities. The company utilises automated testing platforms and offers comprehensive support services including maintenance, technical training, and post-deployment support, along with embedded firmware and hardware development. Recognised as a trusted design house, Shrike Marine delivers end-to-end services from concept through to production. Its ISO certification, technician accreditation, and track record in military-grade assembly position it as a reliable partner for high-performance systems. Global ambitions are strengthened by strategic international partnerships, including collaboration with Qua Systems.

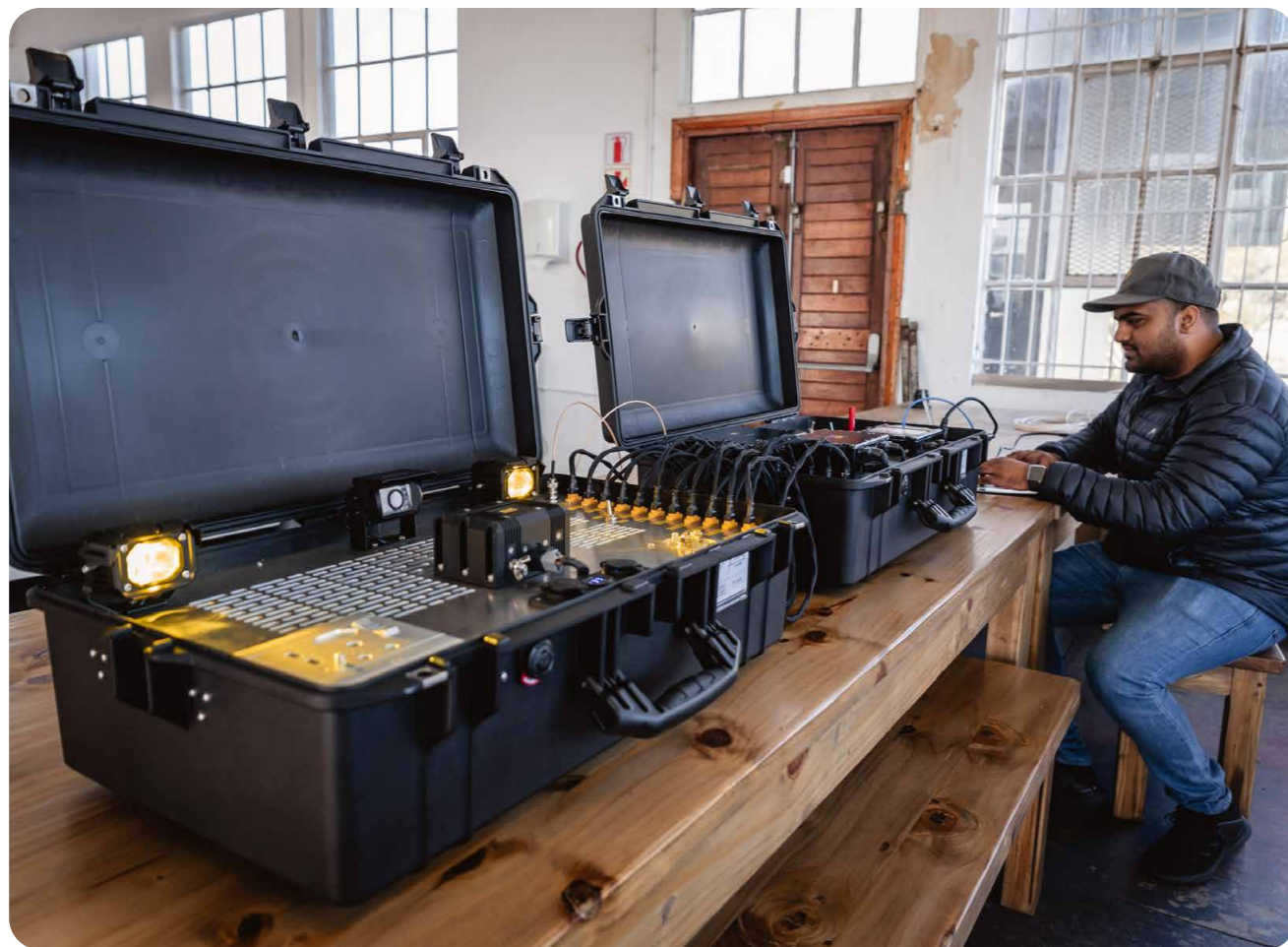

Shrike Marine's Yuveer Naraindass is seen here demonstrating a vehicle power management system.

LUVHONE ENGINEERING

Luvhone Engineering was founded in 2015 by Dr Leago Stella Takalani, a pioneering South African woman engineer. The company has rapidly emerged as a dynamic player in the aerospace, telecommunications, and ICT sectors. This SME offers a wide spectrum of engineering and consultancy services spanning aerospace and space systems, satellite communications and broadcasting technologies, telecom infrastructure, air traffic management, and airport safety systems.



Its technical capabilities include radio frequency (RF) testing across Ku, S, UHF, and VHF bands, the design and commissioning of terrestrial and satellite broadcast systems, and the development of secure IP WAN/LAN networks and enterprise ICT platforms. The company also provides high-level consultancy in R&D, operations, and technology management. A notable regulatory milestone was its licensing by the South African Council for Space Affairs, enabling it to manage space objects in alignment with international obligations.

The organisation's strategic growth is underpinned by key partnerships and forward-looking ambitions. While it has not yet entered the export market, it is actively cultivating trade and technology links in Europe, Asia-Pacific, and the Atlantic region. With a bold NewSpace trajectory, the company is poised to evolve into a mid-cap technology firm within the next decade, driven by a focus on public-sector growth, R&D investment, and a firm commitment to empowering women in STEM and fostering ethical, inclusive innovation.



Dr Leago Stella Takalani is a pioneering engineer and academic leader at Luvhone Engineering, specialising in innovative, sustainable solutions for South Africa's infrastructure and technology sectors. With expertise spanning research, design, and mentorship, she is committed to advancing engineering excellence, youth empowerment, and inclusive industrial growth.

“

Having successfully achieved ISO 9001 and ISO 14001 certification better positions Luvhone Engineering for success on an international platform.

PETRAWELL

Petrawell Pty Ltd is a South African specialist in aviation and aerospace component manufacturing, with a particular focus on composite filament winding technologies. As a highly agile and technically driven enterprise, Petrawell delivers customised solutions for high-performance applications across sectors such as space exploration, pressure vessel engineering, and sports technology.

The company's core expertise lies in designing and executing advanced filament winding processes using tailored materials and equipment to meet unique client requirements. Applications range from hybrid and liquid-fuel propulsion components and structural rocket and satellite bodies, to high-strength storage solutions and sports engineering parts.

Its technology partnerships with leaders in advanced materials and engineering have enabled the development of lightweight,



cost-effective, and robust composite solutions. A significant milestone was achieved in April 2023 with the successful launch of its first filament-wound component into space, reinforcing its credibility in the aerospace sector.

Petrawell aspires to become the preferred provider of satellite and rocket composite components. Its reputation is underpinned by technical excellence, a lean and flexible engineering team, and a strong commitment to innovation and youth development. Through active engagement with students and graduates, such as its recognition of UKZN engineering finalists, Petrawell contributes to nurturing the next generation of aerospace talent. Its integrated project management, space-proven capabilities, and close collaboration with academia and industry place the company at the forefront of South Africa's growing composite manufacturing and space technology landscape.



A Xenon tank produced by Petrawell attached to a hydrostatic test bench

TECHNOLOGY READINESS LEVELS (TRLs) EXPLAINED

Technology Readiness Levels (TRLs) are a systematic framework developed to measure the maturity of a technology, from concept to deployment. The scale runs from TRL 1 (basic principles observed) through to TRL 9 (system proven in operational environment).

TRL 1 – 3:

Research and Proof of Concept:

Early-stage basic science, principles observed, and proof-of-concept models in lab conditions.

TRL 4 – 6:

Prototype Development and Validation:

Technology moves into applied research, with laboratory and pilot-scale testing, leading to prototype demonstration in relevant environments.

TRL 7 – 9:

System Demonstration & Deployment:

Pre-commercial systems tested in operational environments, refined for industrialisation, and scaled for market entry.

Why are TRLs Important?

TRLs are critical in bridging the gap between South Africa's strong research base and its industrial needs. While local universities and research institutions produce world-class innovations, many of these ideas remain stuck at laboratory or proof-of-concept stages. TRLs provide a structured roadmap to guide technologies from early discovery through to market-ready solutions, ensuring that promising innovations do not fall into the "valley of death" between research and commercialisation. By systematically progressing through the stages, South African innovators can build confidence, reduce risk, and demonstrate clear value to potential partners and investors.

South Africa faces a heavy reliance on imported technologies in key areas such as aerospace, defence, renewable energy, and healthcare. A TRL-driven approach enables the country to grow its own intellectual property, strengthen high-tech manufacturing capacity, and build sovereign capability. In doing so, it promotes local innovation while reducing dependency on costly foreign systems. This not only aligns with national objectives for reindustrialisation and economic transformation but also ensures that technological progress directly supports job creation and skills development within the local economy.

TRLs offer policymakers, funders, and industry stakeholders a common language for decision-making. By clearly identifying the maturity of a technology, TRLs make it easier to channel resources effectively, from seed funding at early stages to large-scale investment for industrialisation. They also enhance South Africa's ability to attract global partnerships, as the framework is internationally recognised and helps align domestic innovation with global standards. Beyond their technical function, TRLs create opportunities for young engineers, artisans, and researchers to gain practical experience in advanced manufacturing and product development, ultimately building the skilled workforce needed to drive South Africa's long-term competitiveness.



AEROSPACE AND DEFENCE INDUSTRY DEVELOPMENT AND TECHNOLOGY SUPPORT

Government support for technology development is essential in South Africa because it creates the enabling environment needed for innovation, industrial growth, and socio-economic transformation. By providing policy direction, funding mechanisms, and infrastructure investment, government support reduces barriers to entry for businesses—especially SMMEs—and accelerates the adoption of advanced technologies across sectors. This is particularly important in a developing economy where private sector investment in research and development (R&D) may be limited due to cost and risk.

Strategic government involvement helps align technology initiatives with national priorities such as the National Development Plan, the Industrial Policy Action Plan, and the Just Energy Transition, ensuring that technological progress addresses critical challenges like unemployment, inequality, energy security, and environmental sustainability. Furthermore, targeted support strengthens South Africa’s capacity to compete globally, attract foreign direct investment, and build resilient industries that can adapt to shifting market demands and technological disruptions.

- Ventura Engineering:** Development and Localisation of Advanced Oil Coolers for Land-Based Vehicles in the Defence Sector
- LS Multicopter Projects and Services:** Affordable Radio Frequency Direction-Finding Antenna Solution for band 20 MHz to 8 GHz in the Aerospace and Defence sector
- Lightweight Structures:** Composite Moulding Process Development for Complex Radome Enclosure
- Radar Makers:** Passive Radar Compact Antenna Enhancement
- Kusasa Aerospace:** Drone Payload Delivery System Project
- AAC Space Africa:** Wide-band S-band Antenna for CubeSat TMTC Application
- On Track Technologies:** Rear Electrical Propulsion System
- Avior Labs:** Industrialisation and Commercialisation of the Elevation Drone.
- Simera Sense:** CubeSat – Shock Test Facility Project
- Micromax:** Metal Injection Proof of Concept at Micromax Project
- WBRxS:** Technology Enhancement: from Wide Band Receiver to Wideband Transceiver



VENTURA ENGINEERING

Development and Localisation of Advanced Oil Coolers for Land-Based Vehicles in the Defence Sector

By leveraging additive manufacturing (AM) technology, Ventura Cooling & Ventilation aims to produce a next-generation composite material heat exchanger for use in armoured personnel carriers. This shift addresses a critical capability gap. There are currently no commercially available heat exchangers that use AM, and no local suppliers offer such solutions, resulting in long lead times, high import costs, and limited customisation.

With this project, Ventura aims to achieve a marked change in performance, cost-efficiency, and operational adaptability for oil cooling systems in defence vehicles. The development and localisation of the Advanced Oil Coolers for Land-Based Vehicles project marks a significant innovation in South Africa's defence manufacturing sector.

At the core of the project is the adoption of a gyroid geometry, known for its superior surface area-to-volume ratio, reduced weight, lower pressure drop, and enhanced thermal performance. Unlike conventional shell-and-tube designs, the gyroid structure enables smoother fluid flow, fewer stagnation zones, and improved fouling resistance.

Using 3D computer aided design (CAD) modelling, Ventura has finalised the key design parameters for its first prototype, optimising the geometry to maximise heat transfer efficiency while ensuring compatibility with existing vehicle systems. This design not only improves cooling performance but also enables lighter, more compact units, which are essential for modern defence platforms.

Collaboration plays a central role in the project's progress and impact. Ventura has partnered with Aditiv Solutions, a South African manufacturer of metal additive manufacturing equipment with experience in aerospace and defence applications. Leveraging their expertise and advanced hardware, the team has overcome initial software and processing limitations that constrained complex gyroid modelling. This partnership ensures that both design development and eventual production are anchored in local, high-tech manufacturing capability.

Producing these systems domestically will reduce supply chain vulnerabilities, lower costs, and provide the flexibility to tailor designs to specific operational requirements, capabilities often not possible with imported systems. Furthermore, the use of AM allows for rapid prototyping and iteration, shortening development cycles and enabling faster deployment of optimised designs to the field. This agility is critical for maintaining a competitive edge in both domestic defence and export markets.

The planned next steps include computational fluid dynamics (CFD) simulations, prototype printing, functional testing, and system integration to validate the performance gains predicted in the design phase.

Commenting on the support received from the AISI, Dawid Fourie, MD for Ventura, said: "Through the AISI Project, we've developed the internal skills and capacity needed to design and produce components for the additive manufacturing process, a capability we didn't have before. In addition, the project has strengthened our engineering expertise in thermodynamics and heat transfer, skills that are consistently in demand in the aerospace sector."

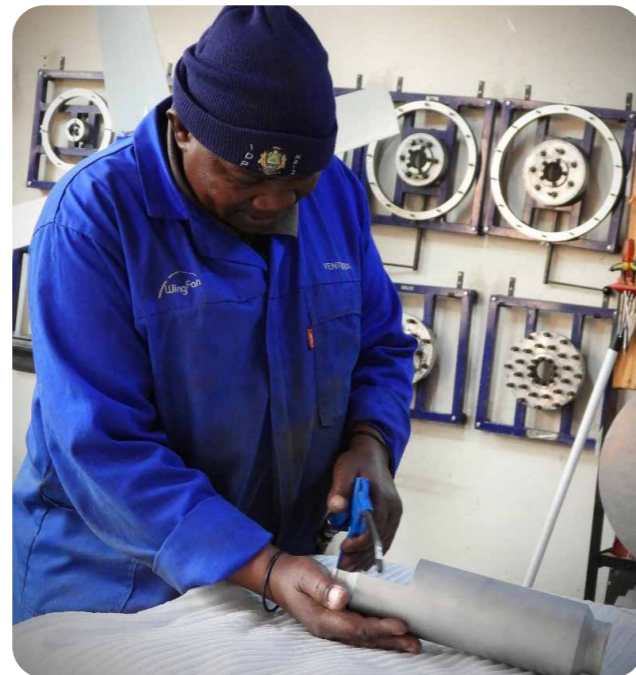

Reuben Mulaudzi is using compressed air to clean printing residue from prototype

PROJECT IMPACT



Innovation and Performance:
Introduces AM-designed gyroid geometry heat exchangers that deliver superior thermal efficiency, reduced weight, and enhanced fouling resistance compared to conventional designs.



Local Capability and Resilience:
Establishes domestic production capacity, reducing reliance on costly imports, shortening lead times, and enabling customised solutions for defence vehicles.



Skills and Industry Growth:
Strengthens South Africa's advanced manufacturing ecosystem by building local expertise in thermodynamics, heat transfer, and additive manufacturing in partnership with Aditiv Solutions.

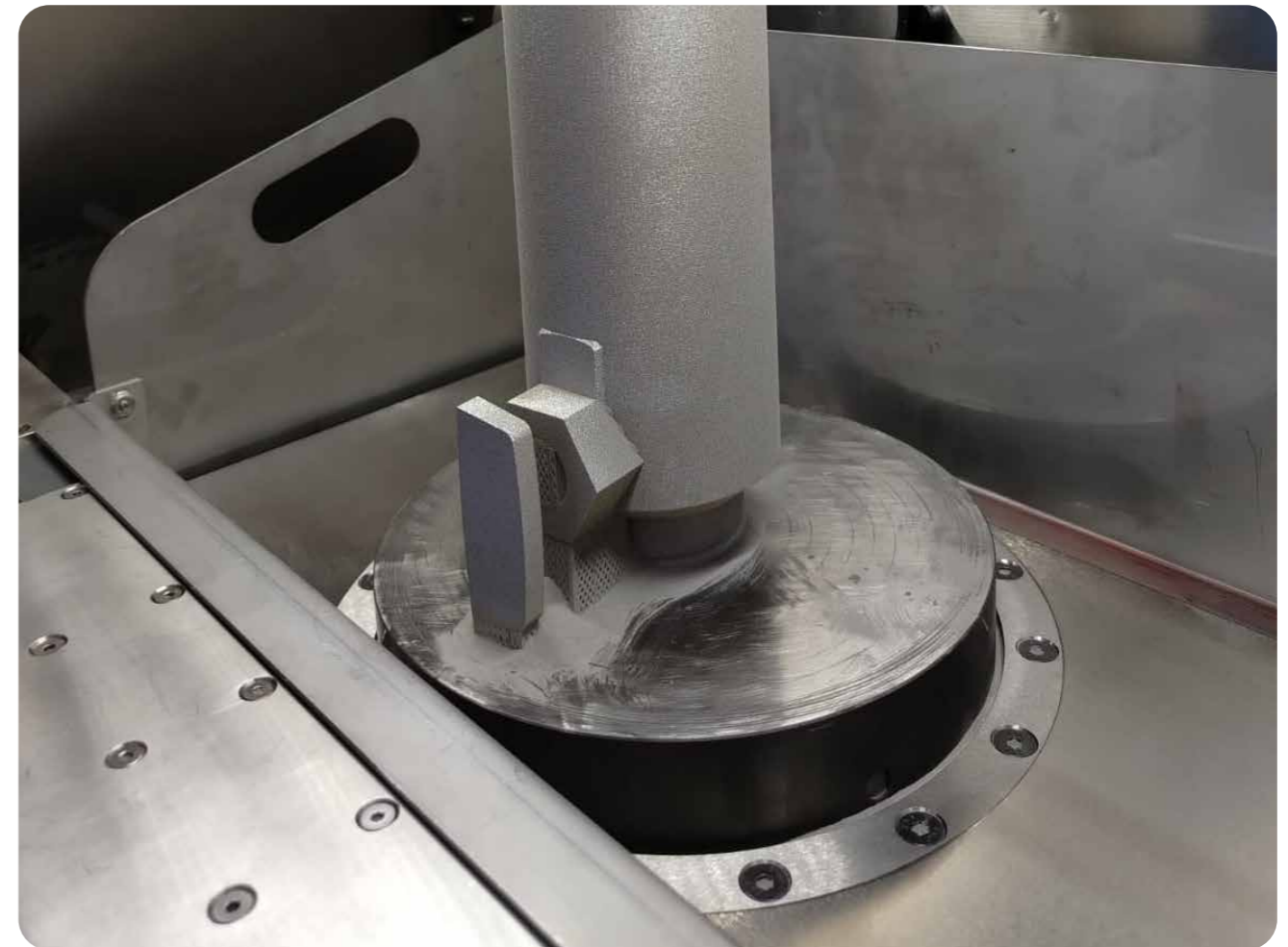

The first printed prototype of the oil cooler (heat exchanger) produced as a result of the support from the AISI

LS MULTICOPTER PROJECTS AND SERVICES

Affordable Radio Frequency Direction-Finding Antenna Solution for band 20 MHz to 8 GHz in the Aerospace and Defence sector.

LS MultiCopter Projects and Services is developing a cost-effective, lightweight Radio Frequency (RF) Direction Finding (DF) antenna and receiver system covering 20 MHz to 8 GHz, including critical bands such as the aeronautical navigation spectrum above 108 MHz. Current DF systems are often prohibitively expensive, limiting their use in security, border control, and other public-sector markets. By delivering an affordable, locally manufactured solution, the project aims to expand access to advanced RF surveillance tools, supporting national innovation, security, and industrial growth.

The DF system will be designed for versatility, deployable in multiple configurations including drone-based aerial units, fixed-site installations, transportable units, and mobile platforms. The drone-integrated option offers a significant advantage by operating above environmental clutter for improved detection and triangulation of illegal or interfering transmissions. Applications will range from RF audits and interference hunting to signal homing and surveillance operations in urban and remote settings, meeting the growing demand for numerous, affordable DF stations in an era of increasing high-frequency usage with shorter propagation ranges.



Michael Mommsen, Nana Agyeman-Duah, Nelson Okafor - Software Development Team

The project's core goal is to create a system capable of identifying and tracking sources of illegal or disruptive RF transmissions, such as unlicensed frequency use, out-of-band transmitters, and malicious jamming. Centralised software control and advanced algorithms will calculate the angle of arrival of RF signals, and when multiple units are deployed together, they will pinpoint exact transmitter locations. Strategically aligned with Advanced Manufacturing and Surveillance and Sensor Systems, the initiative will progress through four phases, inception, hardware and software design, manufacturing and assembly, and testing in both controlled and real-world environments, culminating in a market-ready, reliable, and accurate solution.

LS MultiCopter's multidisciplinary team of engineers, software developers, drone pilots, and designers will drive rapid iteration and technical milestone delivery. The project addresses threats to secure communications, vehicle tracking, public safety, and national defence while advancing homegrown technologies and reducing reliance on imports. Upon completion, the company will introduce a scalable, portable RF DF system suited to public safety, security, and commercial markets, positioning itself as a competitive player in South Africa's high-tech manufacturing and defence sector.

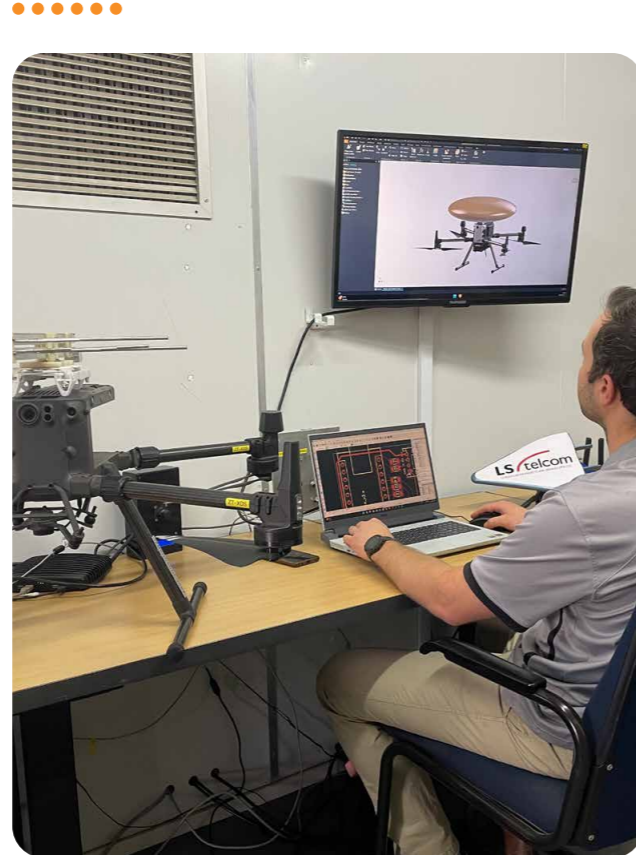

Machiel Carstens - Enclosure Development and Design

PROJECT IMPACT



Affordable Local Solution:
Delivers a cost-effective, locally manufactured RF DF system, reducing reliance on imports.



Enhanced Security and Safety:
Enables detection and tracking of illegal or disruptive transmissions across multiple deployment platforms.



Industrial Growth:
Strengthens SA's advanced manufacturing and defence capabilities through innovation and skills development.



Louwrens Prinsloo - Antenna Design and Calibration

LIGHTWEIGHT STRUCTURES

Composite moulding process development for complex radome enclosure

Lightweight Structures is a South African engineering and manufacturing company that specialises in advanced composite materials and lightweight solutions for demanding industrial applications. Serving sectors such as defence, aerospace, transportation, and renewable energy, the company provides custom-engineered products that combine strength, durability, and reduced mass. Its turnkey offering spans concept design, prototyping, and full-scale manufacturing, advancing local capabilities while supporting skills development, job creation, and international-standard innovation through research and collaboration.

Hensoldt, a global leader in defence and security electronics, selected Lightweight Structures to develop a composite moulded enclosure for a next-generation radar system, with the goal of transitioning from prototype to a stable manufacturing process suitable for serial production. This partnership not only showcased Hensoldt's radar technology as a case study but also marked a critical step in building a reliable local supply chain for precision defence components, boosting local content in radar system assembly.

The project's core challenge lay in creating large, high-tolerance composite enclosures that maintained the radio frequency performance essential to radar operation while ensuring mechanical reliability, environmental sealing, and structural integrity. Early prototypes revealed design and process limitations, which were resolved through engineering refinement, tooling innovation, and supplier process improvements. Meeting stringent defence-grade requirements required Lightweight Structures to expand its expertise and upgrade its facilities to meet the technical demands of the project.

To move from prototype to production, the company delivered a complete systems engineering documentation pack, developed custom tooling and assembly jigs, and produced three fully assembled prototypes, supported by detailed manufacturing instructions and dimensioned drawings for repeatability. The success of this initiative strengthened Lightweight Structures' role in the defence and aerospace sectors, enhanced South Africa's advanced manufacturing capacity, and contributed to long-term technological self-reliance by enabling domestic serial production of precision radar enclosures.

What is a Radome Enclosure?

A radome enclosure is a protective structure that shields radar antennas or sensitive electronic systems from harsh environmental conditions such as rain, wind, salt spray, dust, and temperature extremes, while allowing radio signals to pass through with minimal interference. Made from lightweight, RF-transparent materials like composites or fibreglass, radomes are widely used in defence, aerospace, marine, and telecommunications to ensure reliable system performance without compromising signal quality.



Seen here from left to right are: Chris Adrian, Dr Benjamin Broughton and Elena Broughton

PROJECT IMPACT



Local Defence Capability:
Enabled domestic production of high-precision composite radar enclosures, reducing reliance on imports.



Technological Advancement:
Improved design, tooling, and manufacturing processes to meet stringent defence-grade specifications.



Industrial Growth:
Strengthened SA's aerospace and defence supply chain, boosting skills, jobs, and competitiveness.



Katlego Mashia and Bongo Manku working on the production of composite parts in the Lightweight Structures factory in Pretoria, Gauteng.

RADAR MAKERS

Passive Radar Compact Antenna Enhancement

Radar Makers, in partnership with Peralex, a South African technology company specialising in advanced electronic warfare, radar, and signal processing systems, is spearheading the development of a next-generation antenna array system for compact passive radar applications. The project aims to deliver a fully integrated, six-channel direction-finding (DF) antenna array capable of operating across both digital video broadcasting–terrestrial (DVB-T) and frequency modulation (FM) frequency bands. As part of a broader effort to miniaturise passive radar systems into compact, deployable formats, this initiative positions Radar Makers and Peralex to gain a strong competitive advantage in the growing market for portable radar solutions, where few global offerings currently exist.

Passive radar represents a major evolution in sensing technology. Unlike traditional radar, which emits radio signals, passive radar exploits existing transmissions, such as FM radio and DVB, to detect and track targets. This makes it virtually undetectable, removes the need for regulated spectrum, and enables energy-efficient operations. Successful deployments for aircraft monitoring, especially in low-interference regions like the Karoo, have already demonstrated its effectiveness. Advancing the antenna array is therefore a vital step toward wider commercialisation and operational deployment of this silent radar technology.

The project specifically targets delivery of a manufactured, tested, and verified antenna array optimised for the DVB-T frequency range (470–700 MHz), aiming for Technology Readiness Level (TRL) 8, which indicates readiness for operational use. Alongside this, the RF design of a complementary FM antenna variant is underway. Intellectual property for both designs will remain with Radar Makers, enabling future supply into local and international markets as part of broader system offerings. The scope covers electromagnetic simulations, CAD design, documentation packs, and full-scale production, with verification through laboratory characterisation and live field testing to ensure compliance with performance and reliability standards.

Beyond hardware, the project also enhances the radar platform's software and algorithms, including signal validation, geolocation, and improved DF accuracy, capabilities critical in environments where fixed infrastructure is unavailable. The FM array will follow the same design methodology, with production scheduled after validation of the DVB-T variant. Overall, the project advances the localisation of cutting-edge radar technologies, supporting national defence industrialisation, technological self-reliance, and export competitiveness. By delivering compact, high-performance antenna systems, Radar Makers and Peralex are reinforcing South Africa's position as a leader in global radar and electronic warfare innovation.

What is a Passive Radar System?

A passive radar system is a type of radar that detects and tracks objects by using existing non-cooperative transmissions, such as commercial radio, television, or cellular signals, instead of emitting its own signal. By analysing how these signals are reflected or scattered off targets like aircraft or vehicles, the system can determine their location, speed, and movement. Because it does not transmit, a passive radar is difficult to detect, consumes less power, and can operate covertly, making it especially valuable in defence, surveillance, and air traffic monitoring applications. It also offers cost and environmental benefits by leveraging existing broadcast infrastructure rather than requiring dedicated transmitters.

PROJECT IMPACT



Advanced Local Innovation:
Partnership delivered compact, high-performance antenna arrays tailored for next-generation passive radar.



Global Competitiveness:
Positions South Africa as a leader in radar and electronic warfare technologies through export-ready solutions.

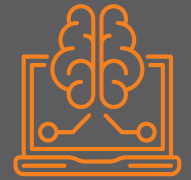

Skills and Capacity Growth:
Strengthens local engineering expertise, fosters youth involvement, and builds a resilient defence technology ecosystem.

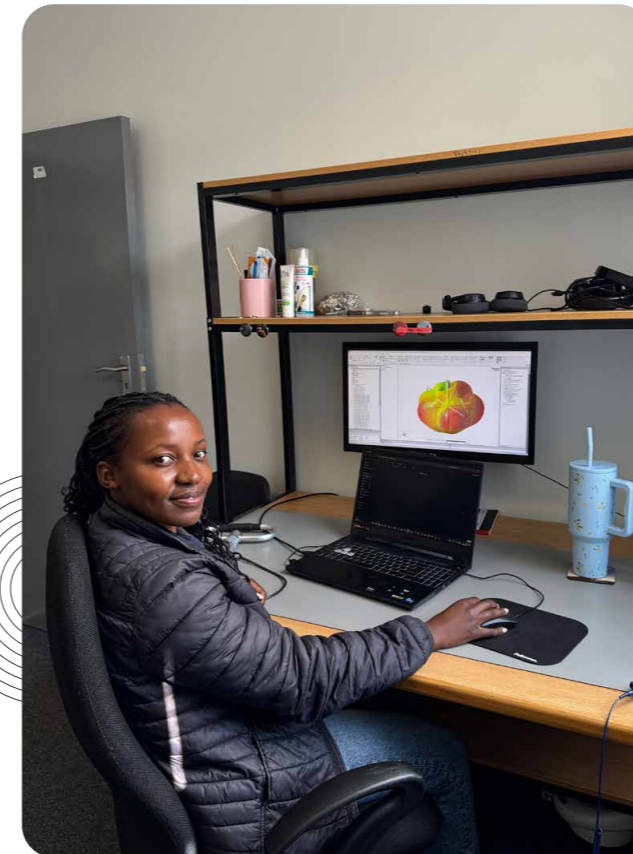

Millicent Mguni, Junior RF Engineer that designed the new compact antenna array



From left to right: Mollatsi Setsubi, Director and Senior Software Engineer that focused on the beamforming and direction finding software algorithms as well as integration with the Peralex Software solution, Johann (Skippy) Burger, Senior RF and Systems Engineer responsible for the full solution, and Millicent Mguni.

KUSASA AEROSPACE

Drone Payload Delivery System Project

A drone payload delivery system offers fast, cost-effective, and flexible transport of goods, enabling time-critical deliveries such as medical supplies, emergency equipment, or high-value items to reach remote, congested, or otherwise hard-to-access areas. By bypassing traditional infrastructure, drones can reduce delivery times, lower operational costs, and operate in conditions that ground vehicles may struggle with, such as poor road networks or disaster zones. Their adaptability to different payload types and compatibility with multiple platforms also expands their utility across commercial, humanitarian, and industrial applications, creating new opportunities for efficiency and service innovation.

In collaboration with the CSIR and AISI, Kusasa Aerospace is spearheading a drone payload delivery system project and Phase 1 has been successfully completed. The initial phase concentrated on market research, stakeholder engagement, and preliminary engineering planning, achieving key milestones that have set a strong foundation for the next stages of development.

Research conducted during Phase 1 has confirmed strong market opportunities in both medical and consumer last-mile delivery, with a particular gap for a flexible, cross-compatible system in the 30kg-class drone category. The new payload delivery system will be designed for compatibility with multiple drone platforms, reducing reliance on specific models and enabling broader adoption across different operational environments.

The design will prioritise safety, operational efficiency, and versatility. It will need to carry at least two 2kg parcels per flight, be easy to load and unload, and incorporate redundancy measures to protect both payloads and people on the ground. The system will also maximise available payload space while integrating seamlessly with its host drone's attachment points, making it adaptable to a wide range of delivery scenarios, including high-value and time-critical missions such as medical supply distribution.

Phase 2 will advance into detailed engineering design, prototyping, and operational testing. This will include computer aided design (CAD) refinement, component sourcing, prototype fabrication, and field trials. Risk mitigation strategies are in place to address supply chain and regulatory challenges, with engagement planned with the South African Civil Aviation Authority once the operational platform is finalised.

If successful, the project will deliver South Africa's first locally developed, cross-platform drone payload delivery system, reducing reliance on imported technology, strengthening local manufacturing capabilities, and unlocking new commercial and humanitarian opportunities across the region.

Alongside the technical work, Kusasa has launched a bursary programme and is planning a graduate programme, ensuring the project contributes to local skills development and knowledge transfer within the aerospace sector.



Peter Clark (left) and Robert Clark (right) are seen here conducting a ground test of the delivery system

PROJECT IMPACT



Innovation and Market Opportunity:
Develops South Africa's first locally designed, cross-platform drone payload delivery system, addressing gaps in medical, humanitarian, and last-mile consumer logistics.



Local Capability and Self-Reliance:
Reduces dependence on imported systems by building domestic design, prototyping, and manufacturing capacity in the 30kg-class drone category.



Skills and Sector Growth:
Supports bursary and graduate programmes to grow local aerospace expertise, ensuring long-term skills transfer and industry development.



The drone utilised for this project is equipped with a coaxial twin rotor. The drone with eight motors in total (four coaxial pairs) is also known as an octocopter.

AAC SPACE AFRICA

Wide-Band S-band Antenna for CubeSat Telemetry/telecommand (TMTC) Applications

AAC Space Africa is the centre of competence for radio frequency (RF) communications within the AAC Clyde Space group, supporting satellite missions across the organisation. As the nanosatellite industry evolves from supplying subsystems to offering turnkey missions—including satellite operation and data delivery—AAC Space Africa plays a vital role in enabling these advanced service models.

To meet the demand for efficient satellite constellations, the company developed an innovative wideband patch antenna designed primarily for CubeSats but also adaptable to larger platforms. This compact antenna operates in the commercial S-band frequency spectrum, supporting both transmit and receive channels with a single unit, streamlining traditional dual-antenna configurations.

The antenna was designed to pair with an S-band TMTC (telecommand/telemetry) transceiver co-funded by the Aerospace Industry Support Initiative (AISI) and completed in February 2024. The integration of the two components created a highly competitive solution for the global New Space market.

Planned over nine months, the project progressed from prototyping to qualification, producing a model rigorously tested for representative space environments and ready for spacecraft integration. The key objectives were to deliver a cost-effective, market-leading design that reduced complexity by consolidating dual antennas into a single unit, ensured compatibility with CubeSats and larger satellites, and advanced the technology readiness level (TRL) from TRL 4 to TRL 7.

The project also supported local transformation and knowledge transfer by partnering with Astrofica Technologies, thereby strengthening the South African aerospace ecosystem and fostering regional skills development. This aligns with AAC Clyde Space's global mission of enabling access to high-quality, real-time space data for applications ranging from weather forecasting and environmental monitoring to precision agriculture. By enhancing the performance, reliability, and affordability of satellite communication systems, AAC Space Africa's work contributes directly to industrial transformation and regional capability development. More broadly, the antenna project reinforces the strategic

importance of a sustainable regional space ecosystem for South and Southern Africa. Such infrastructure can deliver benefits unattainable from earthbound systems, including data for disaster response, food and water security, communication, and navigation.

As AAC Space Africa affirms, investment in space technology represents not only an innovation imperative but also a strategic pathway for sustainable development. The success of this project demonstrates how high-impact innovation can advance both national competitiveness and long-term regional growth.

What are Cube Sats?

A CubeSat is a type of miniaturised satellite built using standardised cube-shaped units, each measuring 10x10x10 cm.

They are lightweight, cost-effective, and can be launched as single units or combined into larger configurations.

CubeSats are widely used for scientific research, Earth observation, technology testing, and commercial space applications.



Prototype of the S-band TMTC transceiver

PROJECT IMPACT

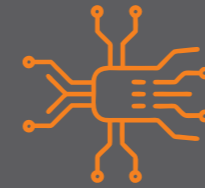

Innovative Technology:
Developed a compact wideband S-band antenna that streamlines satellite communications by replacing dual-antenna setups.



Global Competitiveness:
Positioned South Africa within the growing New Space market through a qualified, space-ready TMTC solution.



Local Capability:
Strengthened the regional space ecosystem via skills development, industrial transformation, and partnerships.

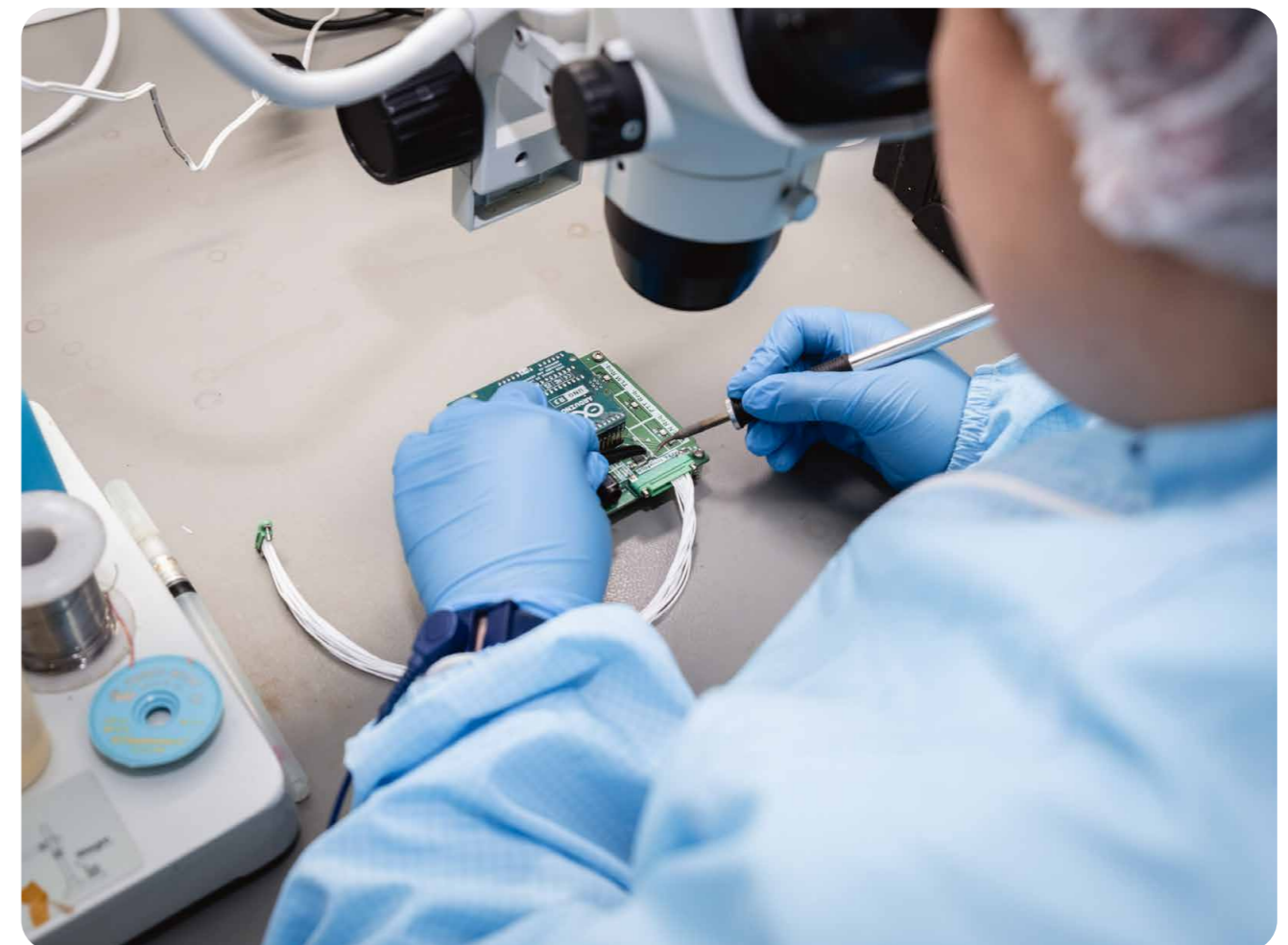

Cynthia Daars, Production Technician, reviewing the prototype

ON TRACK TECHNOLOGIES

Rear Electrical Propulsion System

OnTrack Technologies is advancing a rear electric propulsion system for gliders and light aircraft, positioning itself as a leader in sustainable aviation innovation. The project centres on integrating a fully electric, self-launching propulsion system into the JS2 open class glider, aligning high-performance aviation platforms with renewable energy technologies. This effort responds to global environmental pressures and the need for cleaner mobility, highlighting the technical complexity and transformative potential of electric flight.

Electric propulsion is particularly promising for sailplanes, whose aerodynamic efficiency makes them well-suited to electrification. However, challenges include system weight, battery and component cooling, propeller RPM optimisation, and precise centre-of-gravity management. OnTrack is addressing these within the CS-22 certification framework, which governs the airworthiness of sailplanes and powered sailplanes, ensuring that the system meets international safety and performance standards.

The project's main objective is to design, prototype, and certify a propulsion system that allows gliders to self-launch without tow planes or ground support. This requires multidisciplinary engineering expertise in propulsion and propeller design, retraction mechanisms, prototype fabrication, and performance validation. Significant progress has been made: initial concept and performance analyses were completed on time, detailed designs finalised, and ground testing successfully validated critical metrics. These results have guided further refinement and de-risked later stages, with the next milestone being integration of the propulsion system into a glider airframe for prototype testing.

Beyond technology, the project enhances South Africa's aerospace capability by developing a certifiable electric propulsion solution locally, reducing reliance on imported systems and creating high-value skills and jobs. Success with the JS2 glider will serve as proof of concept for electric propulsion in recreational and light-sport aviation, paving the way for broader adoption across multiple aircraft categories. As OnTrack affirms, this initiative demonstrates how engineering excellence can contribute to aviation decarbonisation, economic growth, and climate resilience.

Benefits of Electric Propulsion Systems in a Glider

Electric propulsion systems on gliders provide significant performance and environmental benefits. Unlike traditional combustion engines, electric motors deliver instant torque, smoother power delivery, and reduced vibration, which enhances flight stability and pilot comfort. They are also quieter, making them ideal for training and recreational environments where noise reduction is critical, and they minimise disturbance to wildlife when operating in natural areas. The efficiency of electric motors allows for reliable self-launching and extended soaring opportunities without the need for external tow assistance, giving pilots more flexibility and independence.

In addition to performance gains, electric propulsion offers clear sustainability advantages. Electric gliders produce zero emissions during flight, contributing to reduced carbon footprints and aligning with global efforts toward greener aviation technologies. Maintenance requirements are lower compared to internal combustion engines, as electric systems have fewer moving parts, resulting in lower operating costs and higher reliability. Furthermore, as battery technology continues to improve, electric gliders are expected to achieve longer endurance and better energy density, further broadening their applications in both sport aviation and pilot training. This positions electric propulsion as a transformative step toward cleaner, more accessible, and more efficient glider operations.



JS2 RES System Ground test bench

PROJECT IMPACT



Sustainable Aviation:
Pioneers a locally developed electric propulsion system, reducing reliance on fossil-fuelled tow planes and imports.

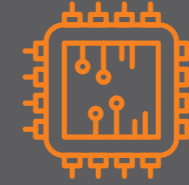

Technical Innovation:
Advances certifiable, high-performance electric flight technology for gliders under international safety standards.



Industrial Growth:
Builds South Africa's aerospace capability, creating skills, jobs, and pathways for broader adoption of electric aviation.



JS2 RES System in the extended position

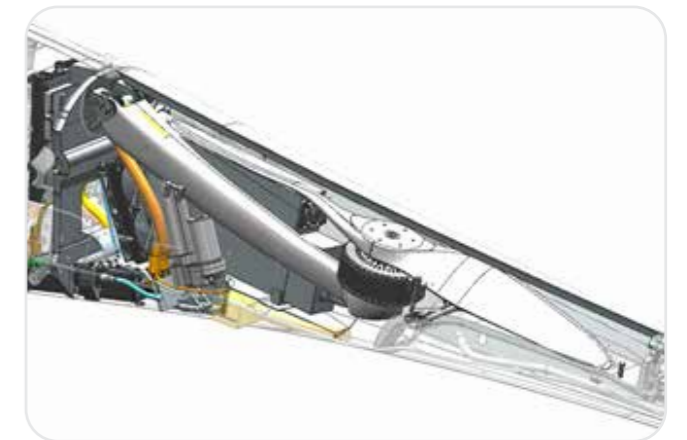

JS2 RES System in the retracted position

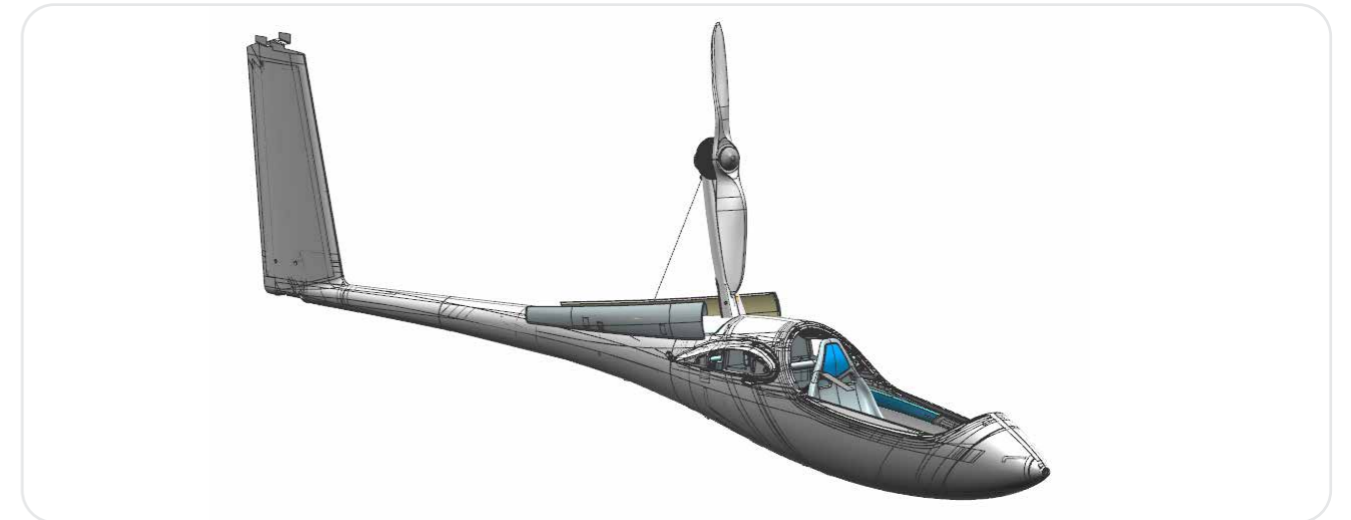

JS2 RES System in the extended position inside the fuselage

AVIOR LABS

Industrialisation and Commercialisation of the Elevation Drone

Avior Labs has advanced the Elevation, a small commercial vertical take-off and landing (VTOL) drone, from early functionality to an industrialisation phase. With support from the AISI, the fuselage was redesigned using a hybrid composite and Expanded Polypropylene (EPP) method, cutting weight, cost, and production time.

The next phase focused on three priorities: embedding datalink antennas to replace commercial ones, upgrading the tail to a moulded shell with integrated control surfaces, and applying the same construction method to the outer wings. These improvements enhanced manufacturability and positioned the drone for greater competitiveness in both local and export markets.

To deliver these goals, Avior Labs partnered with Lightweight Structures, a South African composite engineering specialist, and LambdaG, an advanced antenna design company. Avior Labs, as project lead and IP holder, provided unmanned aerial vehicle (UAV) systems expertise; Lightweight Structures contributed manufacturing capacity; and LambdaG developed and integrated conformal antennas into the composite fuselage.

All objectives were met, with only a minor delay for antenna design refinement. The project strengthened Elevation's readiness for commercialisation while deepening long-term R&D and manufacturing collaboration, supporting job retention and laying the groundwork for growth.

Founded in 2019, Avior Labs develops high-efficiency UAVs for applications in health, agriculture, security, environmental monitoring, and humanitarian operations. In 2021, it formalised its partnership with Lightweight Structures to produce Elevation's structural components, positioning the UAV as a cost-effective platform with longer endurance than multirotor drones and a better price point than international competitors. With production expected to scale from 2024, the project highlighted the importance of innovative and scalable manufacturing processes.

A key innovation was the integration of conformal embedded antennas into the hybrid EPP/composite airframe, reducing drag and improving structural efficiency compared to traditional antennas. LambdaG developed prototypes operating in the

900 MHz IMT band, with future plans to expand into C-band for larger UAVs. This advancement enhances South Africa's aerospace capabilities, enabling participation in global UAV supply chains with cost-effective, high-performance systems. The broader goals include job creation and progress into wider aerospace markets.



Avior Labs has taken its Elevation VTOL drone from early testing to industrialisation, showcasing how local innovation can compete globally. Supported by the Aerospace Industry Support Initiative (AISI), the drone's fuselage was redesigned using a hybrid composite and Expanded Polypropylene (EPP), significantly reducing weight, cost, and production time. Strategic partnerships with Lightweight Structures and LambdaG enabled the integration of conformal embedded antennas and advanced composite components, enhancing performance, manufacturability, and scalability.”



“This initiative represents a major milestone in positioning South Africa's UAV industry for global leadership” Dr Benjamin Broughton, MD for Avior Labs

PROJECT IMPACT



Technological Advancement: Integrated conformal embedded antennas and improved composite structures, enhancing performance and manufacturability.



Market Readiness: Positioned the Elevation UAV for industrialisation and global competitiveness in diverse applications.



Local Growth: Supported job creation, strengthened partnerships, and built South Africa's aerospace supply chain capacity.



The Elevation is a small commercial vertical take-off and landing (VTOL) drone, redesigned with lightweight hybrid composites to reduce cost, weight, and production time while advancing toward industrialisation.

SIMERA SENSE

CubeSat Shock Test Facility

South Africa's growing CubeSat industry faced a major challenge: conventional shock test facilities were designed for larger satellites, forcing local developers to send payloads overseas for testing. This added significant costs, delays, and logistical complexity, while limiting local innovation capacity.

To close this critical gap, Simera Sense (Pty) Ltd embarked on a project to upgrade its CubeSat Shock Test Facility (STF) into a national asset capable of delivering reliable, cost-effective testing under realistic launch conditions. The initiative introduced key improvements such as a digital twin of the facility, an upgraded impact system, automated handling features, and enhanced measurement capabilities, establishing a foundation for long-term industry growth and resilience. Headquartered in Somerset West, Simera Sense has built its



Seen here from left to right are Quiwin Daniels, Test Engineer; Ian Smith, Senior Mechanical Engineer; Timothy Seloane, Project Manager; and Hano Steyn, Lead System Engineer

reputation as a leader in high-performance satellite imaging systems, specialising in modular Earth Observation payloads from 3U to 16U for low Earth orbit missions. These payloads must withstand the extreme mechanical shocks of launch, making rigorous testing essential. By expanding its STF, Simera Sense not only strengthened its own development processes but also created an accessible local solution to support South Africa's wider space innovation ecosystem at a time of rapidly increasing global demand for small satellite technology.

The upgraded STF was designed to deliver precise, reliable testing through several key enhancements. A second impactor and an additional axis were added to reduce handling risks, automated lifting and locking systems improved safety and precision, and vibration measurement capabilities were refined for more accurate results. Alongside these technical upgrades, comprehensive operating manuals and procedures were developed, while the creation of a digital twin enabled real-time monitoring, simulation, and predictive maintenance, showcasing Simera Sense's commitment to innovation and operational excellence.

The impact of this project extends well beyond Simera Sense. The STF now meets international testing standards, giving developers confidence to certify payloads for global deployment. It has also created a collaborative hub for universities, research institutions, and international space actors, enabling advanced R&D and academic participation in satellite innovation.



Space exploration has rapidly emerged as a forerunner in modern technological advancements and whilst one might think that 'bigger is better' when it comes to earth observation the smaller CubeSats, often referred to as nanosatellites, have played an increasingly important role, and in the last decade the launch of CubeSats has increased more than tenfold." Hano Steyn, System Engineering Lead at Simera



PROJECT IMPACT



Local Capability:

Established South Africa's first dedicated CubeSat Shock Test Facility, reducing reliance on costly overseas testing.



Innovation and Excellence:

Introduced advanced features such as a digital twin, automated systems, and improved measurement for world-class reliability.



Ecosystem Growth:

Strengthens the regional space sector by enabling R&D, skills development, and international-standard certification.



Conventional satellite shock testing facilities have historically catered to large satellites. In South Africa, there is limited access to specialised testing resources tailored to CubeSat requirements

MICROMAX

Metal Injection Proof of Concept at Micromax

The Council for Scientific and Industrial Research (CSIR) has played a pivotal role in advancing the metal injection moulding (MIM) project in partnership with Micromax and the Aerospace Industry Support Initiative (AISI). A key milestone was the successful establishment of the CSIR MIM Industrial Facility at Building 46F, marking a major step in transitioning the technology from a laboratory-scale environment to an industrial context.

This achievement required extensive preparatory work, including site readiness, safety compliance, and the installation of essential infrastructure for gas, electricity, and cooling systems. These efforts have created a strong foundation for building a sustainable local capability in MIM technology.

Significant technical progress was achieved through the relocation and commissioning of the Arburg injection moulding machine and the installation of the debinding and sintering (DBS) furnace at the new industrial facility. These steps enabled the CSIR team to produce the first prototype actuator parts for Micromax, with detailed characterisation confirming that the sintered components met the required quality standards. The successful production of these green and sintered parts provided vital proof-of-concept validation for the feasibility of local MIM manufacture, bridging the gap between research and industrial application.

Parallel to facility development, progress was also made on the design and manufacture of tooling for Micromax components. The moulds for the pressure actuator parts were designed and produced in-house by Micromax, while the CSIR team provided technical support to refine their performance on the Arburg machine. In addition, design drawings for the base plate component were completed, setting the stage for further prototyping. These collaborative efforts underscored how Micromax's product knowledge and CSIR's process expertise could be combined to drive innovation.

One of the most important outputs of the project was the development of a detailed costing model for the CSIR MIM process. This model benchmarked the locally produced components against the cost of importing parts from China and the cost of processing CSIR-produced green parts overseas. The results were encouraging, showing that locally

manufactured MIM components compared favourably with imports and held the potential to become more cost-effective at higher production volumes. This insight not only validates the competitiveness of local manufacturing but also strengthens the business case for Micromax to invest in full-scale MIM capability.

From a CSIR perspective, the project represents a major milestone in the development of advanced manufacturing technologies in South Africa. The establishment of the industrial MIM facility, coupled with successful prototype production and cost benchmarking, signals the readiness of local institutions to support industry in diversifying manufacturing capability.

As Estiaan van der Merwe, Contract Manager at Micromax, emphasised: "The establishment of the CSIR MIM Industrial Facility and proof-of-concept manufacture of the Micromax parts represent a significant milestone towards the industrialisation of MIM technology in South Africa."

This initiative not only reduces reliance on imports but also positions South Africa to compete in global aerospace and defence supply chains by adopting innovative, cost-efficient, and high-value manufacturing technologies.

What is Metal Injection Moulding?

Metal injection moulding is a manufacturing process for producing complex components at high speeds and a significantly reduced cost. It is a metalworking process in which finely-powdered metal is mixed with a binder material to create a feedstock. The feedstock is then solidified and shaped to produce the final product.



Prototype components produced through metal injection moulding (MIM) will advance South Africa's local capability to supply high-precision parts for the aerospace and defence sectors.

PROJECT IMPACT



Local Capability:
Established South Africa's first industrial-scale MIM facility, reducing reliance on imports.



Competitiveness:
Produced prototype components at costs comparable to overseas suppliers, with potential for lower costs at scale.



Industry Growth:
Created a foundation for commercial MIM adoption, enabling new opportunities in aerospace, defence, and advanced manufacturing.



The CSIR's Mandy Madigoe, a Senior Engineer and Technical Leader on the project, is seen here preparing an Arburg MIM machine to produce green components.

WBRXS

Technology Enhancement: From Wideband Receiver to Wideband Transceiver

Wideband Receiver Solutions (WBRxS) TRX-6G4S Project sought to develop an advanced radar transceiver system with ultrawide bandwidth capabilities. Building on WBRxS' earlier SP-6G4S wideband receiver module, the system was enhanced into a complete solution capable of high-speed analogue-to-digital (ADC) and digital-to-analogue (DAC) conversion for radar and other RF applications. Key upgrades included two additional ADC input channels, a new FireFly optical transceiver module, and a high-performance DAC capable of generating RF signals from DC to beyond 6 GHz, depending on the Nyquist zone.

With four ADC channels, the TRX-6G4S could be configured for full-bandwidth operation at 3 GHz or split into four channels at 750 MHz each, enabling flexible deployment across radar, signal intelligence, and other RF tasks. At its core is a Kintex Ultrascale+ FPGA, which manages digital signal processing (DSP), integrates custom algorithms, and supports lower-bandwidth outputs like spectrometer data. High-speed data links via four serial transceivers support 40 GbE or 100

GbE, ensuring fast data transfer, while both ADC and DAC are time-synchronised to an external reference for stability and coordinated multi-system operation.

WBRxS leveraged its extensive expertise, including its role in developing digitisation systems for the MeerKAT radio telescope, to adapt advanced radio astronomy technologies for defence, aerospace, and telecommunications. The TRX-6G4S addresses radar challenges such as signal drift, complexity, and high costs by using direct digitisation to replace fragile heterodyne systems, simplifying architectures while improving robustness. This innovation makes the system highly versatile for both local and international applications.

The project followed four structured phases: planning and component sourcing, detailed design, prototype development and testing, and final product qualification. Two fully functional units were produced and delivered, along with a complete manufacturing data pack. By advancing radar transceiver technology, the TRX-6G4S strengthens South Africa's position in RF and signal processing innovation and establishes WBRxS as a leader in delivering next-generation radar solutions for global deployment.

The Nyquist Zone Explained

The Nyquist zone refers to the frequency range in which a signal can be accurately sampled without aliasing, based on the sampling rate of the system. Specifically, the first Nyquist zone spans from 0 to half the sampling frequency, while higher zones represent successive frequency bands beyond this range where signals can still be reconstructed using appropriate techniques.



See here are Henno Kriel, Renier Siebrits and Sias Malan, who collectively bring an extensive amount of knowledge to the business

PROJECT IMPACT



Advanced Capability:
Delivered a next-generation radar transceiver with ultrawide bandwidth, enhancing flexibility and performance.



Local Innovation:
Adapted radio astronomy expertise into defence and aerospace applications, reducing reliance on complex, costly systems.



Global Competitiveness:
Positioned South Africa as a supplier of cutting-edge RF and radar technologies for international markets.

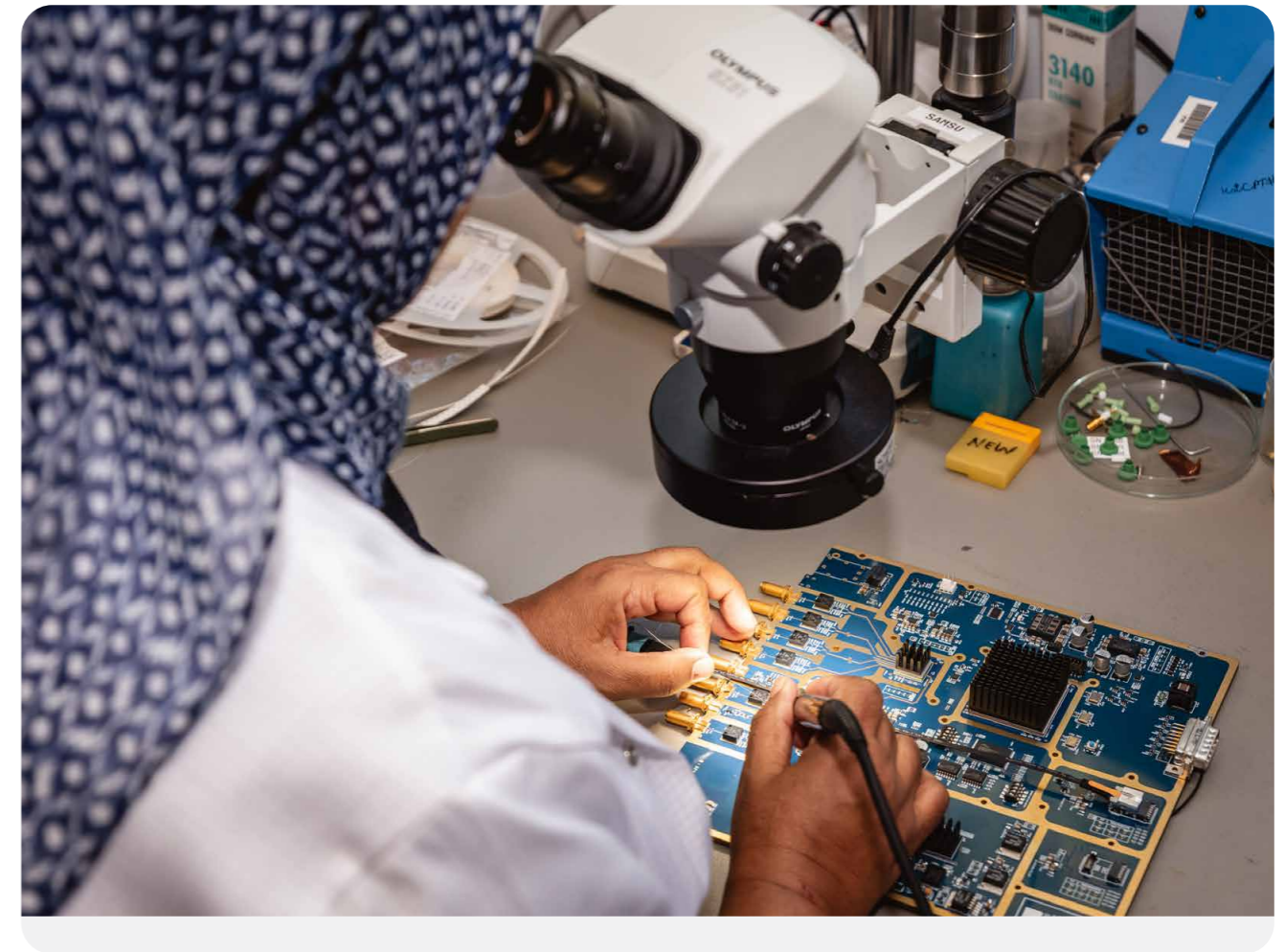

Final inspection of completed transceiver PCB by Samsunissa Fataar.

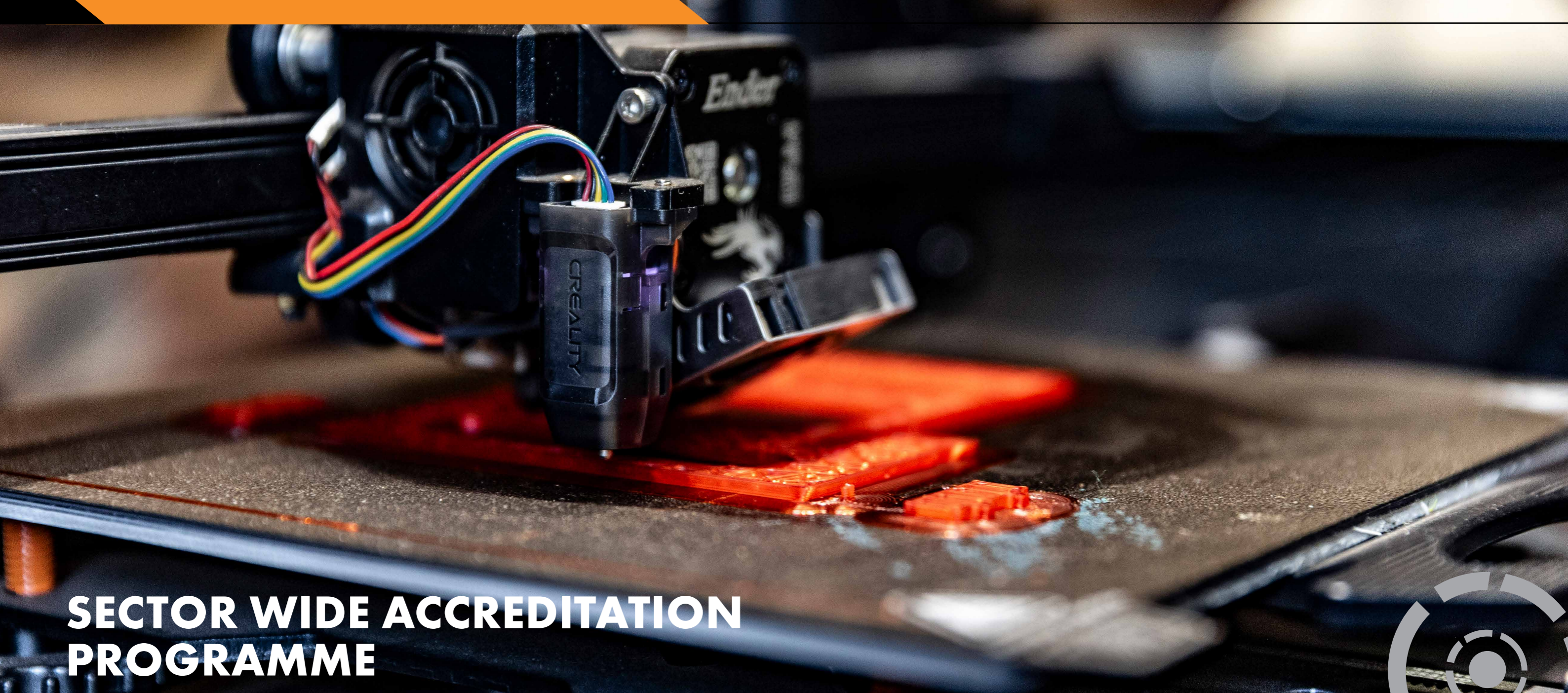

SECTOR WIDE ACCREDITATION PROGRAMME

TECHNOLOGY ENHANCEMENT



The AISI's Sector-Wide Accreditation Programme – Technology Enhancement supports companies in advanced manufacturing sectors, including aerospace, defence, and marine, to achieve internationally recognised standards and certifications while upgrading their technological capabilities.

By assisting businesses, particularly SMMEs, to meet stringent quality, safety, and performance requirements such as ISO and sector-specific accreditations, the programme enables greater access to local and global markets, strengthens competitiveness, and ensures compliance with regulatory frameworks. In the South African context, this initiative is a catalyst for industrial growth and transformation, as it not only enhances operational efficiency and product quality but also fosters technology adoption, innovation, and skills development.

By aligning accreditation support with technology enhancement, the programme helps broaden the industrial base, integrate more local suppliers into high-value supply chains, and position South Africa as a trusted source of world-class, technology-driven products and services.

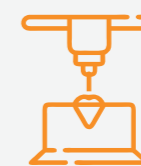

Ulmo Water: Modular Dissolved Air Flotation Reactor Product Development

Skills Instruments: Manufacturing Minimal Invasive Cardiac Instruments

Feasible Plastics: Tooling for Large Injection Moulded Bolt and Nut for Floating Solar Assembly



ULMO WATER

Modular Dissolved Air Flotation Reactor Product Development

Ulmo Water (Pty) Ltd is a Cape Town-based EPC (Engineering, Procurement, and Construction) contractor specialising in decentralised water and wastewater treatment solutions. The company designs and manufactures compact, modular treatment plants tailored to a variety of municipal and industrial environments. Emphasis is placed on high-quality, cost-effective systems with a focus on long-term durability and low maintenance.

Its turnkey design-build services support treatment capacities of up to 5 megalitres per day (MLD), offering technical solutions such as clarification, media filtration, desalination for brackish water, and advanced biological modules like Membrane Bioreactors (MBR), Moving Bed Biofilm Reactors (MBBR), and Dissolved Air Flotation (DAF).

The company is supported by a small, multidisciplinary team of professionals registered with the Engineering Council of South Africa (ECSA), including engineers, draftsmen, and production specialists. A notable example of their work is the installation of bioreactor plants treating 300 kL/day of wastewater in the Paarl-Franschhoek Valley for eco estate developments. With a proven track record across South Africa, Ulmo Water is positioning itself as a trusted innovator in sustainable and decentralised water treatment infrastructure.

The development of the modular Dissolved Air Flotation (DAF) system for integration with the wastewater treatment plant (WWTP) of a poultry farm based in North West has advanced significantly, with key milestones in fabrication, procurement, and assembly having been successfully completed.

AISI funded project progress was achieved across all work packages, including the successful procurement of several critical components. Fabrication of the DAF tank, including sandblasting, coating, and mechanical fit-out, has been finalised and the control panel was fully assembled with human-machine interface (HMI), switchgear, motor starters, and PLC integration, while the stainless steel pipework design and installation were also successfully completed.



The electrical-fit-out phase that includes installation of wiring, power distribution, and control system integration, and the factory acceptance testing (FAT) phases commenced concurrently and during the reporting period, the project experienced no major deviations from the planned timeline. By the end of the financial period the project was firmly on track, progressing towards full validation and deployment.

" AISI's support has been a game-changer for Ulmo Water, enabling us to develop our very own Dissolved Air Flotation (DAF) system. The successful completion of this project has reduced our reliance on imported technologies, built local expertise through skills development of our team and collaborators, and developed our competitive position in South Africa's market." - Bongani Chichava, Manufacturing Engineer.



Top view of the DAF in operation, showing the flocculation tanks with mixers and the flotation chamber with scraper flight

PROJECT IMPACT



Local Innovation:
Developed a modular DAF system, reducing reliance on imported technologies.



Skills and Capacity Building:
Enhanced local expertise through engineering and technical skills development.



Market Competitiveness:
Strengthened SA's position in decentralised water treatment solutions.



The completed DAF, featuring a flotation tank, chemical dosing tanks and MBBR bioreactor

SKILLS INSTRUMENTS

Manufacturing Minimal Invasive Cardiac Instruments

Skill Surgical Instruments is a specialised South African medical device company supplying a wide range of surgical instruments to both public and private hospitals. With deep clinical insight and strong healthcare partnerships, the company expanded from distribution into local manufacturing—starting with neurosurgical instruments—marking a key strategic shift toward building domestic production capacity. This evolution has positioned Skill Surgical as a trusted provider of high-quality, locally made products tailored to the specific needs of surgeons and hospitals across the country.

Recognising a gap in the availability of cardiovascular surgical instruments, the company has, over the past four years, invested significantly in advanced manufacturing equipment and technical expertise to meet growing local and global demand. Supported by a well-established distribution network, Skill Surgical is now poised to introduce a range of domestically produced cardiovascular instruments, a move that addresses escalating import costs and prolonged international lead times.

In direct response to these market pressures, the company has prioritised the local manufacture of four high-demand Minimal Invasive Cardiac Instruments—Needle Holders, Knot Pushers, Scissors, and Suction Tubes—which were traditionally imported from Germany. To ensure world-class quality, technicians underwent specialised training in Germany and now manage South Africa’s only high-level repair facility for such instruments—one so advanced that even competitors rely on its services.

Backed by South African Health Products Regulatory Authority (SAPHRA) manufacturing licences and a substantial investment in precision equipment including a 4-axis milling machine, CNC lathe, and laser welder, the company operates a fully owned, debt-free facility. This infrastructure, combined with partnerships with local service providers, will accelerate tool development and production scalability. In doing so, Skill Surgical is not only improving product availability and reducing

import dependency, but also contributing meaningfully to the resilience of South Africa’s healthcare system and the growth of its medical manufacturing sector.

What is SAHPRA?

SAHPRA is an independent public entity established under South African law to regulate the safety, efficacy, and quality of health products for both human and animal use. Its responsibilities include licensing manufacturers and distributors of medicines, medical devices, and radiation emitting equipment; overseeing clinical trials; and enforcing radiation safety regulations.



Assembly of the jaw parts and inspection of the laser welding performed to join the pull rod and the jaws outer housing .

PROJECT IMPACT



Import Substitution:
Local manufacture of high-demand cardiovascular instruments reduces dependency on costly imports and long lead times.



World-class Capacity:
Investment in precision equipment and specialised training positions SA as a producer of globally competitive surgical tools.



Healthcare Resilience:
Strengthens local medical manufacturing, improving availability and supporting South Africa’s health system.



Machining of the handle



The front jaws are joined to the pull rod using laser welding and will then be inserted into the outer tube



The parts that are assembled in the factory and ready for assembly

FEASIBLE PLASTICS

Tooling for Large Injection Moulded Bolt and Nut for Floating Solar Assembly

Feasible Plastics (Pty) Ltd is a dynamic South African SME established in November 2020 through the strategic merger of BDM Plastics and RM Plastics. Based in Rosslyn, Pretoria, the company was founded by five directors: Bushy Mahadulula, Martin Thobejane, Rachel Rallele, David Bolayi, and Silas Rallele, with a shared vision to innovate within the plastic injection moulding sector.

Since inception, Feasible Plastics has evolved from a small-component manufacturer into a competitive supplier for high-demand sectors such as automotive, aerospace, medical devices, home appliances, and packaging. The company continues to build on its foundation of technical excellence and industry responsiveness.

Offering end-to-end injection moulding services, including custom mould design, tooling, and finishing, Feasible Plastics is distinguished by its quality output and ability to manage complex projects. Its portfolio includes millions of precision components delivered to major clients, supported by a skilled team and advanced manufacturing equipment. The Small Enterprise Development Agency (SEDA) has played a vital role in the company's growth, providing marketing, technical support, and branding assistance that enabled facility upgrades and increased production capacity. With plans underway for ISO 9001:2015 certification and premises expansion, Feasible Plastics is positioning itself as a scalable, trusted supplier within both domestic and regional markets.

The project supported by the AISI sought to secure the necessary tooling and qualify the manufacturing process for producing injection moulded bolts and nuts specifically for the Floating PV Systems market. Unlike current imports, the locally produced components will be designed to meet specific structural requirements not yet addressed by existing products. This targeted innovation not only offers a cost-effective, locally manufactured solution but also enhances supply chain resilience and reduces dependency on imported components.

The broader goal of the project is to establish a sustainable production line for large injection moulded bolt and nut components, primarily intended for assembly in floating solar panel systems, but with wider applications in other sectors.

The commissioning of production tooling will allow for the manufacturing of test pieces and eventual market rollout.

With an existing client base and export facilitation underway, Feasible Plastics is well-positioned to expand its footprint in the renewable energy sector, supporting local industrial development and contributing to South Africa's green economy goals.

"The support received from the CSIR, the Aerospace Industry Support Initiative (AIS), and the Department of Trade, Industry and Competition (DTIC) has been instrumental in helping us meet one of our biggest challenges, developing custom moulds to meet specific client requirements. This assistance enabled us to design and produce a mould tailored to a key client's needs, giving us a competitive edge, driving business growth, and creating new job opportunities. Access to similar funding in the future would further strengthen our ability to innovate, differentiate ourselves from competitors, and unlock new market opportunities," says David Bolayi of Feasible Plastics.



Plastic nuts and bolts are increasingly used in floating solar assembly because they solve several practical and technical challenges that arise in harsh aquatic environments:

Corrosion Resistance – Unlike steel or other metals, plastic fasteners do not rust or corrode in constant contact with water, ensuring long-term durability and reducing maintenance costs.

Lightweight & Buoyancy – Plastic components are much lighter than metal ones, helping to reduce overall system weight and support the buoyancy of floating platforms.

Electrical Insulation – Being non-conductive, plastic nuts and bolts reduce the risk of stray current corrosion and enhance electrical safety in solar systems operating on water.

Cost-Effectiveness – They are generally cheaper to produce, easier to transport, and simpler to install in large volumes compared to specialised stainless steel fasteners.

UV and Chemical Resistance – Specialised engineering plastics are formulated to withstand prolonged exposure to sunlight, chlorine, and other chemicals present in reservoirs, dams, or industrial water bodies where floating solar is deployed.

PROJECT IMPACT



Localisation and Resilience:
Developed custom tooling for injection-moulded bolts and nuts, reducing reliance on imports.



Green Economy Support:
Provides cost-effective components for floating solar systems, advancing renewable energy adoption.



SME Growth:
Strengthens SA manufacturing capacity, driving competitiveness, job creation, and export potential.



Seen here from left to right are: Wayne Wiid (left), David Bolayi (center), and Gary Wiid (right).





SECTOR WIDE: STANDARDS AND ACCREDITATION

.....

In an industrial manufacturing environment, Industrial Standards Organisation (ISO) standards are important because they provide a consistent framework for ensuring quality, safety, and reliability across operations. Manufacturing processes often involve complex systems, machinery, and materials, and without clear standards, the risk of errors, defects, and safety incidents increases significantly. By adhering to ISO standards, companies can minimise variability, reduce waste, and deliver products that consistently meet customer requirements, strengthening both efficiency and trust.



New Vision Engineering: ISO 9001, ISO 14001 and ISO 45001 Implementation
Nicro Pump and Valve: ISO 9001 and SABS Certification for Valves
Khentsa Specialised Tube: ISO 9001:2025 Quality Management System

ISO standards also support compliance with national and international regulations, which is critical in industries that operate across borders. For manufacturers, this not only reduces the risk of legal or financial penalties but also opens access to global markets where certification is often a prerequisite. In addition, ISO standards drive continuous improvement by encouraging regular audits, reviews, and the integration of best practices into everyday operations. This ensures that companies remain competitive in rapidly evolving industrial sectors.

Beyond quality and compliance, ISO standards help foster a culture of accountability and transparency within manufacturing environments. They provide employees with clear guidelines, roles, and responsibilities, which enhances teamwork, safety awareness, and operational discipline. Furthermore, ISO standards can strengthen stakeholder confidence—whether investors, partners, or customers—by demonstrating that the organisation follows internationally recognised benchmarks for excellence. In this way, ISO standards are not just about technical specifications but also about building long-term sustainability and competitiveness for manufacturers.

NICRO PUMP AND VALVE

Implementation of ISO 9001:2015 QMS

Nicro Pump & Valve (Pty) Ltd, established in March 2008 and based in Germiston, Gauteng, is a privately owned South African engineering firm and a key division of the Nicro Industrial Group.

The company specialises in the design, manufacture, and refurbishment of pumps and valves for demanding industrial applications in sectors such as petrochemical, mining, chemical processing, paper, fertiliser, power, marine, cement, and wastewater treatment. Leveraging in-house foundry and machining capabilities, Nicro produces a wide range of high-performance products, including centrifugal and peristaltic pumps, furnace components, submerged-arc furnace parts, and precision-engineered valves—such as fire-safe ball valves compliant with BS 6755 Part 2 standards.

With a strong focus on engineering excellence, Nicro Pump & Valve is supported by a multidisciplinary team of engineers, machinists, and technical experts who consistently deliver customised, high-quality solutions. The company's integration within the broader Nicro Holdings Group enhances its ability to provide end-to-end industrial services—from design and fabrication to refurbishment and installation. Currently pursuing ISO 9001 certification with support from AISI, Nicro aims to further solidify its quality management systems. Backed by a clean financial record, operational stability, and a customer-first approach, Nicro Pump & Valve is strategically positioned to expand its impact across South Africa's industrial landscape.



NewVision Engineering

Implementation of ISO 9001:2015 QMS, ISO 14001:2015 EMS and ISO 45001:2018 OHSMS

NewVision Engineering (Pty) Ltd, headquartered in Vereeniging, Gauteng, specialises in engineering and steel fabrication solutions across a broad spectrum of industries, including mining, agriculture, rail, renewable energy, food processing, water and sanitation, and civil infrastructure.

The company operates from a modern, fully equipped workshop with overhead cranes capable of lifting up to 10 tons, enabling efficient 24-hour production. With a team of over 40 skilled artisans and technical professionals, NewVision delivers comprehensive services ranging from design and precision engineering to custom fabrication and on-site installation.

With its National Black Business Council (NBBC) certification affirming its status as a non-fronting, black-owned enterprise, NewVision Engineering stands as a model of inclusive industrial



growth. The company prioritises both operational excellence and meaningful empowerment by investing in employee development and cultivating strong client partnerships.

Its offerings extend to structural steel fabrication and heavy machinery leasing, positioning it as a versatile, full-service provider. Through a combination of technical capability, empowerment-driven leadership, and a commitment to quality, NewVision Engineering is poised to contribute significantly to South Africa's infrastructure development and socio-economic transformation.

KHENTSA SPECIALISED TUBE

The Provision of Consulting Services to Implement ISO 9001:2015 QMS

Khentsa Specialised Tube (Pty) Ltd, founded in May 2023 and headquartered in Klerksoord, Pretoria, is a Black woman-owned South African manufacturer specialising in thermal and oxygen lancing tubes. Serving critical sectors such as steel, mining, smelting, chemicals, and state-owned enterprises, the company provides high-performance tubing for use in extreme industrial environments, including blast furnaces and induction systems.

Khentsa also offers complementary equipment such as ball valves, braided hoses, and fire-resistant PPE, delivering turnkey solutions that prioritise safety and durability. With a skilled local team and technical support from initiatives like the AISI, Khentsa



has developed in-house innovations, including a hydrostatic pressure tester to enhance product reliability and quality control.

As part of its growth and professionalisation strategy, Khentsa is implementing an ISO 9001:2015 Quality Management System.

Certification is currently underway to align with global quality benchmarks. The company's operational strategy balances industrial efficiency with a commitment to local economic empowerment and environmental sustainability. With strong technical capacity, certified processes, and a focus on job creation, Khentsa is well positioned to expand into broader markets while remaining a trusted local supplier to South Africa's heavy industries. with Qua Systems.

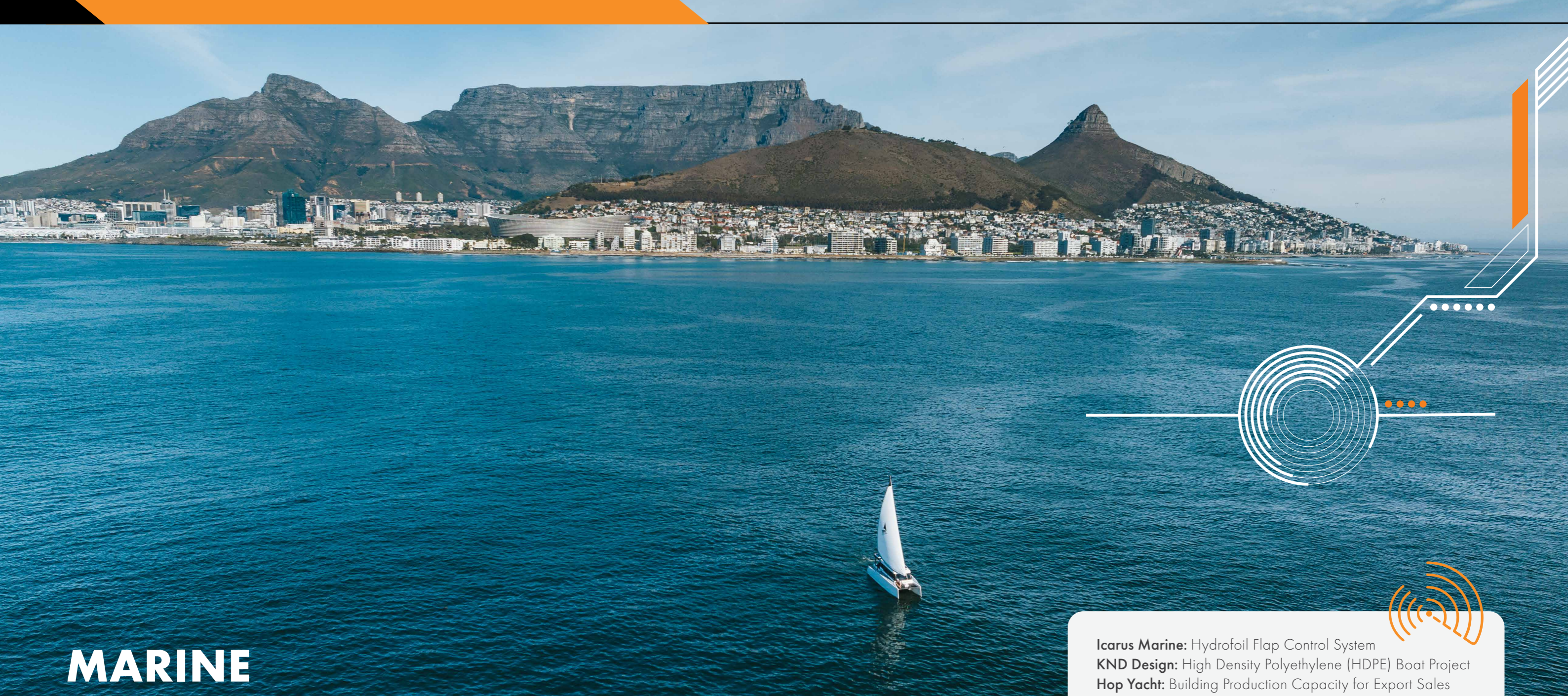

MARINE TECHNOLOGY ENHANCEMENT



Technology enhancement in South Africa's marine environment is crucial for unlocking the country's ocean economy potential, protecting marine ecosystems, and improving operational efficiency across shipping, fisheries, offshore energy, and coastal management.

- Icarus Marine:** Hydrofoil Flap Control System
- KND Design:** High Density Polyethylene (HDPE) Boat Project
- Hop Yacht:** Building Production Capacity for Export Sales
- Ibis Manufacturing:** Rubber Pilot Step Ladder Manufacturing Process
- Symbytech:** Argonót: Development of an Underwater UAV

With its strategic location along major global shipping routes and an extensive coastline rich in biodiversity and resources, South Africa benefits significantly from adopting advanced marine technologies such as satellite-based vessel tracking, autonomous underwater vehicles (AUVs), precision navigation systems, and digital port management platforms. These innovations improve safety at sea, optimise logistics, combat illegal, unreported, and unregulated (IUU) fishing, and support sustainable aquaculture practices.

In the South African context, technology enhancement also strengthens the objectives of Operation Phakisa's Oceans Economy initiative by enabling more accurate environmental monitoring, early detection of marine pollution, and improved climate change resilience for coastal communities. By integrating modern engineering, robotics, data analytics, and renewable ocean energy solutions, the country can diversify its maritime industries, create high-value jobs, and position itself as a competitive player in the global blue economy while ensuring the long-term health and productivity of its marine resources.

ICARUS MARINE

Hydrofoil Flap Control System

Icarus Marine's hydrofoil flap control system project represents a significant step forward in high-speed marine vessel technology. By developing an in-house flap control system for hydrofoils, Icarus Marine aims to address a market gap. The system's ability to adjust lift dynamically will allow operators to fine-tune vessel performance according to sea conditions and speed, improving efficiency, stability, and passenger comfort. This innovation positions South Africa to offer a unique turnkey hydrofoil package that combines advanced mechanical design, software intelligence, and local manufacturing expertise.

From an environmental and operational impact perspective, this technology supports global trends toward green maritime solutions. Hydrofoils significantly reduce drag by lifting the hull partially or fully out of the water, lowering fuel consumption and emissions. Icarus' approach keeps the hull in contact with the water for propulsion simplicity while using adjustable flaps to adapt lift and trim. This hybrid method improves energy efficiency without requiring a complete redesign of existing vessel propulsion systems, making it a more accessible upgrade for commercial, leisure, and military operators.

Icarus Marine, with over 18 years of hydrofoil expertise, will conduct the design and integration work in Cape Town, supported by Skeg Product Development. The development of a proprietary control solution reduces reliance on imported, non-specialised hardware, enhancing long-term competitiveness and export potential.

The project will also have technological and skills development benefits. It integrates mechanical engineering, electronics, software programming, and user interface design into a single marine system. Engineers will design compact actuators capable of independent port and starboard control for roll stability, develop a marine-suited dashboard display for real-time flap monitoring, and create control algorithms adaptable to a wide range of vessel types.

Lab testing with simulated sea conditions will ensure the system's readiness for deployment, with field testing planned when a suitable client vessel becomes available.

"This product is designed to add further value to our hydrofoil offerings, which are primarily focused on the overseas market. Our client base spans every continent except South America, and our intention is to begin actively marketing the product once development is complete," comments Gunther Migeotte, Executive Director for Icarus Marine. "At this stage, we are not offering it to clients because it is essential that, when we do, it is fully tested and proven reliable. We already have an early adopter lined up who is prepared to implement the product on one of their vessels."

Benefits of a Hydrofoil Flap on a Catamaran

A hydrofoil flap on a catamaran provides enhanced performance by dynamically adjusting the lift generated by the foils, allowing the vessel to optimise stability, speed, and efficiency under varying sea conditions. By controlling the angle and shape of the hydrofoil, the flap helps fine-tune how much of the hull is lifted out of the water, reducing drag significantly. This not only improves fuel efficiency or reduces energy consumption in electric or hybrid systems but also increases top speeds and enhances the smoothness of the ride by minimising wave impacts. For racing or high-performance catamarans, these benefits translate into superior manoeuvrability and consistent performance across a wide range of speeds and sea states.

Beyond speed and efficiency, hydrofoil flaps also play a crucial role in passenger comfort and safety. By maintaining optimal trim and balance, the system reduces pitching and rolling, resulting in a smoother and more stable ride, even in choppy waters. This enhanced stability can expand the operational envelope of catamarans, making them more reliable for commercial applications such as ferries or offshore support vessels, where passenger comfort and fuel economy are equally important. In essence, hydrofoil flaps combine performance, efficiency, and comfort, making catamarans more versatile and competitive in both recreational and commercial maritime sectors.

PROJECT IMPACT



Innovation and Competitiveness:

Local development of a proprietary hydrofoil flap control system will reduce reliance on imported hardware and position South Africa as a supplier of turnkey hydrofoil solutions.



Efficiency and Sustainability:

Improves vessel performance, fuel efficiency, and passenger comfort while supporting global trends in green maritime technologies.



Skills and Technology Development:

Advances local expertise by integrating mechanical, electronic, and software engineering into a single marine system, strengthening export potential and industry capacity.



A hydrofoil-supported catamaran reduces drag by lifting its hulls partially out of the water, resulting in higher speeds, improved fuel efficiency, and enhanced stability. This system delivers a smoother ride in rough conditions while lowering operational costs and increasing overall performance.

KOBUS NAVAL DESIGN

High-density Polyethylene Boat Project

KND Naval Design's high-density polyethylene (HDPE) Boat Project addresses a critical gap in Africa's inland waterway transport sector by delivering a safe, durable, and environmentally responsible vessel. Built from 100% recyclable HDPE, the boat is designed to withstand harsh weather, resist corrosion, and offer minimal maintenance requirements.

Its robust construction, coupled with unsinkable design and suitability for both displacement and planing modes, provides an affordable and dependable solution for local fishermen, transport operators, and tourism ventures. This initiative directly supports safer, more reliable access to underutilised waterways, improving mobility and economic opportunities in communities where conventional boats are often unsuitable.

The project's technical innovation lies in the application of advanced naval architectural design methods, including computational fluid dynamics (CFD) analysis, hydrostatics, stability testing, and structural load assessments, all tailored to the unique properties of HDPE. The team used precision computer numerical control (CNC) cutting, specialised welding schedules, and stringent quality controls to produce a platform that meets demanding operational standards.



State of the art CAD and CNC cutting software used for designing and producing the components required for the boat production

While certification is planned for a later stage, the boat has been developed to align with international safety requirements, enabling future access to export markets. The combination of durability, adaptability, and eco-friendliness positions the HDPE vessel as a game-changer for both domestic and international small craft markets.

From an economic and industrial impact perspective, the project promotes local manufacturing and skill development. By designing the platform for modular construction, KND Naval Design enables pre-cut components to be shipped for assembly by trained local builders, reducing labour costs and supporting regional job creation. This approach empowers small manufacturers across the continent, fostering knowledge transfer in marine-grade HDPE welding and vessel assembly.

The environmental benefits are equally significant. HDPE's recyclability and resistance to marine growth reduce the need for toxic antifouling treatments and minimise environmental degradation. The material's long service life and low maintenance needs mean fewer replacements and less waste over time.

By substituting traditional boat-building materials such as fiberglass, which has higher production emissions and is non-recyclable, the project supports a circular economy and advances green manufacturing practices in the marine sector.

Its combination of safety, sustainability, and cost efficiency makes it a viable choice for humanitarian aid, disaster relief, eco-tourism, and small-scale commercial operations. With the AISI's support, the vessel has been successfully designed and manufactured, marking a milestone in African maritime innovation. By showcasing the product at industry events and building strategic partnerships, KND Naval Design can expand its reach, boost export potential, and position South Africa as a leader in sustainable small craft solutions, turning a local innovation into a regional and global opportunity.



CNC machine operator, Fabian Kinnear, cutting the locating tabs to be able to remove the CNC cut components from the sheet of virgin HDPE

PROJECT IMPACT



Safety and Accessibility:
Provides a durable, unsinkable, and low-maintenance vessel that improves safe access to inland waterways for fishing, transport, tourism, and community mobility.



Sustainability and Environment:
Utilises 100% recyclable HDPE, reducing reliance on non-recyclable materials like fiberglass and supporting circular economy and green manufacturing practices.



Local Manufacturing and Skills Development:
Promotes modular construction and regional assembly, creating jobs, transferring marine-grade HDPE welding skills, and strengthening Africa's boatbuilding capacity.



Nicolo Farmer, a senior fabricator and member of KND Fabrications, is seen here operating a plastic extrusion welder. This tool is essential for fusing HDPE plastic with a welding filament, ensuring strong and reliable joints in fabrications.

HOPYACHT

Building Production Capacity for Export Sales

The HopYacht production capacity expansion project is designed to address both current manufacturing bottlenecks and long-term market opportunities for the HopYacht 30, an innovative, all-electric catamaran targeting export markets. Its primary goal is to design and produce a new set of high-quality production moulds, especially for the cabin and hulls, that will ensure consistent build quality, reduce construction time by at least three weeks, and enable the annual output to grow significantly.

This shift is essential to meet the growing demand in Europe and North America, where the HopYacht 30's eco-friendly features and unique demountable hull design position it in a niche market segment with limited competition.

In terms of impact, the project is expected to transform HopYacht's operational capacity and strengthen South Africa's marine manufacturing reputation globally. By replacing the

deteriorating prototype cabin mould with a robust, two-part fibreglass mould, the company will drastically cut recurring repair time, improve surface finish quality, and extend the mould's lifespan from fewer than 10 units to over 20. This not only boosts production efficiency but also enhances product quality and customer satisfaction, helping maintain a premium position in the export market.

From a skills development perspective, the project incorporates in-house training for the mould production team and internships for young talent, such as an intern from the Lawhill Maritime Centre. These opportunities ensure knowledge transfer in advanced composite mould-making, precision measurement, and computer aided design. This investment in human capital directly supports South Africa's industrial growth agenda, particularly in fostering specialised marine industry skills that align with sustainable, electric-powered vessel manufacturing.

Progress to date has been substantial despite early challenges and the preliminary design phase is complete. The next phase will focus on completing the cabin mould, fast-tracking the simpler hull moulds to finish within the same period, and commencing the testing and validation stage.

Once these milestones are achieved, HopYacht will be positioned to meet increased export demand efficiently, reduce per-unit production time and cost, and reinforce South Africa's standing as a leader in innovative, sustainable marine manufacturing. This combination of technological upgrade, workforce development, and market expansion underscores the project's strategic significance for both the company and the broader sector.



Side view of the first cabin produced from the mould

PROJECT IMPACT



Operational Efficiency and Quality:

New high-quality moulds will reduce construction time by three weeks per unit, extend mould lifespan, and improve surface finish, boosting production efficiency and customer satisfaction.



Export Growth and Competitiveness:

Expanded capacity enables HopYacht to meet rising international demand in Europe and North America, strengthening South Africa's reputation in sustainable marine manufacturing.



Skills Development and Innovation:

Provides hands-on training and internships in advanced composite mould-making and design, fostering specialised skills aligned with the growth of electric-powered vessel manufacturing.



Front view of the first cabin produced from the mould

IBIS MARINE PRODUCTS

Rubber pilot ladder step manufacturing development

With support from the AISI, Ibis Marine Products has successfully redesigned its pilot ladder step, transforming it from a heavy, costly, and slow-to-produce component into a lighter, more durable, and sustainable product. The project focused on replacing the traditional wooden step with a compression-cast rubber version incorporating recycled tyre crumb and glass fibre reinforcement. This change reduced weight by over 50%, circumvented wood procurement issues, and optimised the entire manufacturing process from casting to assembly. The redesigned step meets ISO 799 specifications and is positioned for both local and export markets once certified.



Whilst conventional pilot ladders make use of the tread and four poppets as separate components, a simplified assembly process has been developed that means the Sure Step is integrated into one single component. The product is also designed to make use of aluminium crimps for tying the treads in place as opposed to older ladders that would be tied together using twine.

Key efficiency gains stem from streamlined moulding, reduced post-processing, and faster assembly using aluminium crimping instead of rope binding. Production time for a 10m ladder dropped from 900 minutes to 240 minutes, enabling Ibis to scale output to meet stock and bulk export demands. The compression casting process was chosen over injection moulding due to lower tooling costs, in-house production control, no minimum order quantities, and higher recycled content use, ensuring better alignment with sustainability and small business cashflow requirements.

Industry benefits include a lower-cost, more resilient product that is easier to maintain, with improved grip and visibility for safety. The use of recycled car tyres supports environmental goals and stimulates demand for local rubber crumb suppliers. Additionally, the shift to an all-in-one rubber step design removes the dependency on increasingly scarce wooden components, mitigating supply chain risks. The new design also offers international competitiveness potential, especially in markets where quick replacement and compliance with stringent safety standards are priorities.

Socio-economic benefits centre on job creation and skills development, as the product is entirely hand-made and suitable for production by unskilled labour with training. The anticipated scaling of production will create employment for youth, women, and black workers, while building in-house expertise in compression casting and product quality control. The project further contributes to import substitution by enabling local manufacture of a component previously sourced internationally, and positions Ibis as a stronger SMME in the marine safety sector.

Pilot step ladders play a critical role in the marine environment by enabling safe and reliable transfer of marine pilots, crew, and inspectors between ships and smaller vessels, often in challenging sea conditions. They are essential for boarding operations in harbours and at sea, where large vessels cannot dock directly and pilots must embark or disembark to guide navigation. Designed to meet strict international safety standards, pilot ladders provide a stable, non-slip platform that ensures secure footing even in wet, dynamic conditions.

Their construction must balance strength, durability, and compliance with regulations to withstand the harsh marine environment, including saltwater exposure, heavy use, and variable weather. Beyond operational safety, pilot ladders are also critical for ensuring uninterrupted global trade, as they form part of the vital infrastructure that supports port operations, cargo movement, and maritime safety compliance.

PROJECT IMPACT



Efficiency and Sustainability:

Reduced ladder production time by over 70% through a lighter, recycled rubber design, cutting costs, minimising supply chain risks, and supporting environmental goals.



Industry Competitiveness:

Delivered a durable, ISO-compliant step with improved safety features, positioning Ibis for both local growth and export market opportunities.



Socio-Economic Development:

Created opportunities for job creation, youth and women employment, and skills development in sustainable manufacturing processes.

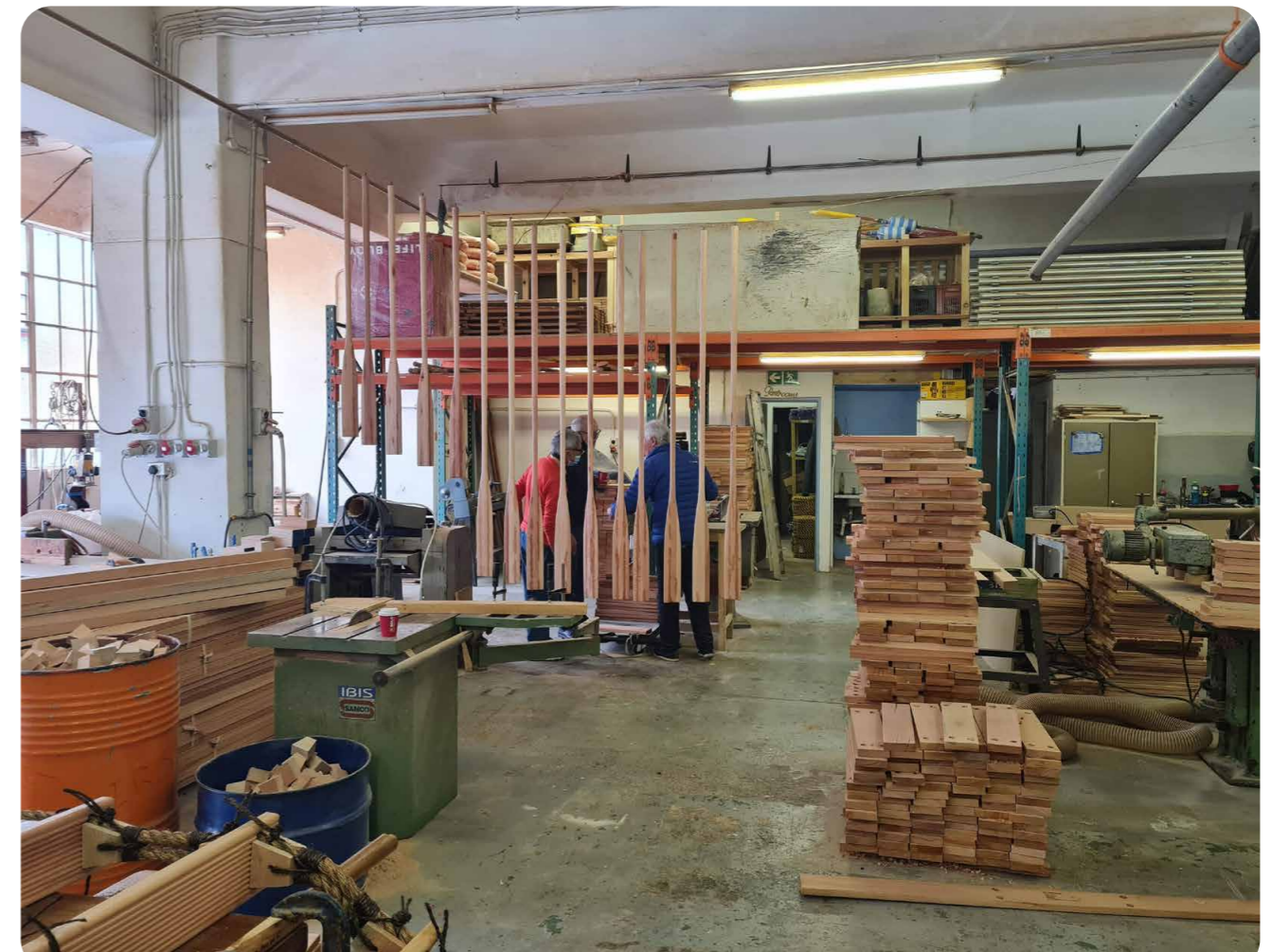

From its factory in Woodstock, Cape Town, IBIS Manufacturing has established a reputation for the production of quality products for use in the marine industry.

SYMBYTECH ARGONÓT

Development of Manned Underwater Vehicle

The Argonót manned underwater robotic vehicle is being developed by Symbytech to address the global challenge of biofouling, a problem that increases vessel drag, fuel consumption, greenhouse gas emissions, and the spread of invasive marine species. This has significant environmental and economic consequences, making the need for an effective, sustainable, and standards-compliant solution critical.

Argonót is designed as a multifunctional robotic device, which means that it adds far greater value than just hull cleaning. Whilst the current focus is on validating its ability as an early-stage robot, future plans are to continue enhancing its capabilities with AI components that allow Argonót to navigate autonomously while being able to be aware of its surrounding by recognising features, structures and organic materials such as marine growth. This will be achieved using Machine Learning and other software and hardware technologies.

These benefits position it as a pioneering South African technology with both national and international market potential. The AISI support for the project is focused on enhancing Argonót from a technology readiness level (TRL) 4 to a TRL6/7.

During the reporting period, the project has focused on stabilising the design, refining hardware and software systems, and conducting rigorous testing. A major milestone has been the development of the Argonót Smart Control (ASC), which coordinates propulsion, lighting, and mission payloads through a network of microcontrollers. Integrating in-house and partner-developed software with multiple hardware subsystems was complex, but successful system communication has resulted in improved stability and operational performance, bringing Argonót closer to operational readiness.

Challenges such as South Africa's unstable power supply and electronic failure due to lower grade chips are being addressed.

"Hardware development has followed an iterative approach, with "controlled breaking" phases used to identify weaknesses and guide design improvements," comments Grant du Toit from Symbytech. "Through the implementation of adaptive solutions, the ultimate goal is more resilient electronics,

simplified designs, and a workshop operation powered largely by renewable energy."

By turning supply chain constraints into opportunities, the team has developed more efficient systems that outperform earlier prototypes. Partnerships with universities, engineering firms, and software providers have enriched the project, while manufacturing techniques such as computer numerical control (CNC) milling, laser cutting, and custom component fabrication have ensured precision and quality. The electronics have been designed with redundancy and adaptability in mind, meeting the demanding standards of global maritime authorities including BIMCO, Glofouling, IMO, and IACS.

Looking ahead, Symbytech is preparing to launch an extended pilot programme to demonstrate Argonót's capabilities across sectors such as fisheries, shipping, oil and gas, and renewable energy. This is expected to strengthen South Africa's maritime service offerings, create economic opportunities, and boost competitiveness in underwater maintenance and inspection services. With a dedicated push towards certification and commercial deployment, Argonót aims to deliver measurable environmental, operational, and economic impact both locally and globally.

What is Biofouling?

Biofouling is the accumulation of aquatic organisms, such as algae, barnacles, mussels, and other marine life, on submerged surfaces like ship hulls, offshore structures, and underwater equipment. This growth increases drag, reduces vessel speed and fuel efficiency, raises greenhouse gas emissions, and can damage equipment. It also facilitates the spread of invasive species, disrupting ecosystems and causing significant environmental and economic impacts for industries reliant on marine operations.

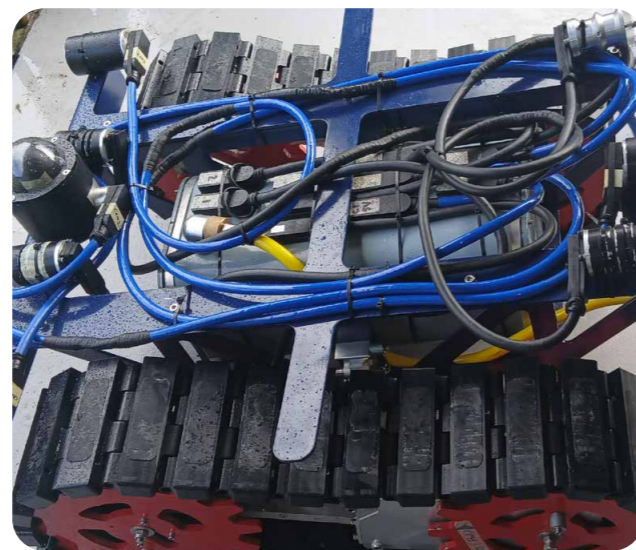

Argonót is designed as a multifunctional robotic device, which means that it adds far greater value than just hull cleaning.

PROJECT IMPACT



Environmental Impact:
Argonót tackles biofouling, reducing vessel drag, fuel use, emissions, and invasive species spread.



Technological Innovation:
Combines robotics and smart control systems to deliver advanced, standards-compliant underwater solutions.



Economic Growth:
Positions South Africa as a global player in maritime robotics, creating opportunities across shipping, energy, and fisheries sectors.



From left to right: Grant du Toit, Founder of SymbyTech, Joseph, general hand for the day, no affiliation with SymbyTech, Mathew Wagner, Mechanical Engineer, Technician and Operator, Eddie Noble, Business Advisor and Mentor. Eddie owns Noble Concentric Solutions and Odin Maritime



MARINE:

STANDARDS AND ACCREDITATION

.....
Marine accreditation in South Africa is essential for ensuring that vessels, equipment, and marine-related services meet internationally recognised safety, quality, and environmental standards, enabling the country to compete in the global maritime industry. Compliance with frameworks such as the International Maritime Organization (IMO) conventions, South African Maritime Safety Authority (SAMSA) regulations, and sector-specific certifications enhances the credibility of local shipbuilders, repair yards, offshore service providers, and port operations.

Accreditation not only facilitates access to international markets but also supports sustainable ocean resource management by promoting best practices in safety, pollution control, and operational efficiency. For South Africa's blue economy, particularly under Operation Phakisa, robust accreditation systems are vital for attracting foreign investment, growing export potential, and ensuring that marine industries operate at a standard that meets both domestic and international regulatory requirements.

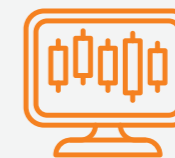

- Naude Industries:** ISO3834 Welding Quality System
- Polyfix:** ISO 9001 with built in ISO 12944-5 Compliance and ISO 14001 Environmental Management System Implementation and 2) CORISSA Training for Paint and Corrosion Protection.
- Surcotech:** Thermal Spray Certification
- Prostar Paints:** Implementation of ISO 17025 and Type Approval of Paint and Facilities
- Carbontech:** ABS Approved Carbon Fibre Pipe Repair Schemes



Why are Standards and Accreditation Important in a Marine Environment

Accreditation and adherence to recognised standards are critical in the marine environment, especially within the South African context, where vast coastal infrastructure and a growing maritime economy demand consistent safety, reliability, and environmental protection.

South Africa's strategic location along major global shipping routes and its reliance on ports like Durban, Cape Town, and Ngqura for trade and logistics make it essential to maintain high standards across marine engineering, shipbuilding, maintenance, and offshore operations. Accreditation ensures that service providers comply with international norms, reducing the risk of failures, accidents, and environmental harm in harsh and corrosive marine conditions.

Given the exposure of marine structures to saltwater, wind, humidity, and temperature fluctuations, the integrity of materials and protective coatings becomes paramount. Adherence to the requisite standards help ensure that engineering processes, coating systems, and material selection are fit for purpose. Accreditation bodies verify that these standards are applied correctly, confirming that welds, coatings, and structural components meet stringent performance criteria. In South Africa, this is especially relevant for shipyards, oil and gas platforms, harbours, and port facilities that require long-term resilience and safety.

Environmental compliance is another key reason for standards in the marine industry. South Africa is a signatory to several international maritime agreements, including MARPOL and the

International Maritime Organization (IMO) conventions, which set strict regulations on emissions, ballast water treatment, and pollution prevention.

IACS (International Association of Classification Societies) certification signifies that a ship or marine structure complies with internationally recognised safety and technical standards. This certification, issued by an IACS member, is crucial for ensuring seaworthiness, regulatory compliance, and insurability in global maritime operations.

Accreditation enhances credibility and market access. Marine operators, contractors, and manufacturers that meet international standards are more competitive in securing public contracts, insurance coverage, and international business opportunities.

In South Africa, where transformation and empowerment are also strategic priorities, accredited enterprises that meet technical, safety, and B-BBEE standards are better positioned for inclusion in local supply chains and government-led marine projects. Overall, standards and accreditation uphold safety, performance, environmental sustainability, and economic opportunity in South Africa's maritime sector.

NAUDE INDUSTRIES

Implementation of ISO3834 Welding Quality System

Naude Industries (Pty) Ltd is a Cape Town-based engineering firm specialising in marine, industrial, and general fabrication services. Established in 2016 by Leroy Naude, a qualified boilermaker with years of experience at DCD Marine Cape Town, the company operates from a fully equipped workshop in Lansdowne Industria, with the flexibility to deploy mobile teams for on-site and offshore work. Naude Industries focuses on turnkey solutions in steel and pipe fabrication, mechanical repairs, scaffolding, blasting, painting, and ship repair, catering to clients like Transnet National Ports Authority and SAMSA.

The core employee base is supported by access to a wider pool of skilled workers. The company delivers dynamic, round-the-clock services for marine vessels, offshore platforms, and industrial facilities. Its hands-on approach combines practical experience with modern technologies, and the firm is working towards obtaining various ISO certifications of which one is the ISO 3834 to enhance quality, safety, and environmental standards. This commitment positions Naude Industries as a trusted, agile provider capable of meeting complex engineering requirements in the South African marine and industrial sectors.

About ISO 3834

ISO 3834 is an international quality management standard for fusion welding of metallic materials, covering all aspects from personnel qualifications and equipment to procedures, inspection, and documentation to ensure consistent, verifiable quality. Because welding is considered a "special process" whose quality cannot always be confirmed by final inspection, ISO 3834 embeds quality into the process itself. Widely applied in industries such as construction, shipbuilding, energy, transport, and aerospace, the accreditation helps manufacturers reduce failure risks, ensure traceability, and demonstrate compliance with international standards, thereby enhancing safety, reliability, performance, and customer trust.

POLYFIX

ISO 9001, ISO 12944-5, ISO 14001 and CORISSA Training

Polyfix (South Africa) is an industrial services company based in Sandton, offering specialised solutions across the mining, civil engineering, and industrial coatings sectors. With over eight years of experience, the company delivers tailored services such as tailings dam management, filter drain installations, penstock piping, piezometer installations, and slurry line jet rodding.

Their civil and engineering services include concrete and piping repairs, chute fabrication, roofing, and insulation, serving the operational and maintenance needs of complex industrial environments. In addition to its mining and engineering capabilities, Polyfix is known for its advanced industrial coatings and corrosion protection services. This includes active leak sealing and specialised surface protection technologies designed to extend asset life and reduce maintenance costs. With a strong presence across mining, oil and gas, and heavy industrial sectors, Polyfix combines technical expertise with durable, cost-effective solutions, making it a trusted partner in infrastructure resilience and plant integrity.

Unpacking the Certifications Supported by the AISI

An integrated management system that combines ISO 9001, ISO 12944-5, and ISO 14001 creates a strong framework for quality, environmental control, and corrosion protection in industrial operations. ISO 9001 drives efficiency, continual improvement, and customer satisfaction, while ISO 12944-5 provides detailed guidance for protective paint systems in different corrosivity environments, supported by inspections and performance tests such as dry film thickness and adhesion checks. Together, they help extend asset lifespan and reduce failure risks.

ISO 14001 complements this by embedding environmental accountability, addressing issues like VOC emissions, hazardous waste, and pollution linked to coating processes. To build industry-wide competence, the Corrosion Institute of Southern Africa (CORISSA) offers certified training aligned with global standards such as ISO 12944, NACE, and SSPC, ensuring professionals across the corrosion protection value chain maintain high standards of safety, quality, and environmental stewardship.

SURCOTEC

Thermal Spray Certification

Surcotec (Pty) Ltd, based in Bellville, Cape Town, has been the Western Cape's longest-operating provider of thermal spray and surface engineering solutions since 2000, offering services from its 1 000 m² workshop that include combustion powder spray, High Velocity Oxy-Fuel (HVOF), plasma spray, Plasma Transferred Arc (PTA) cladding, precision machining, grinding, super-finishing, bore welding, and on-site refurbishment.

Surcotec is positioned as a trusted partner for industries requiring precision wear and corrosion protection. In sectors like marine engineering, where infrastructure faces constant exposure to saltwater, fluctuating temperatures, and mechanical stress, compliance with international standards is essential, not only for technical performance but also to strengthen legal

and financial protection, build stakeholder confidence, and promote environmental stewardship. In the competitive global marine market, such verified compliance is often a prerequisite for securing tenders, insurance, and classification, making accreditation both a marker of excellence and a driver of long-term sustainability and growth.

To ensure coatings are applied safely and consistently, thermal spray certification verifies the competency of individuals, organisations, and processes, with three main types: personnel certification, process and facility certification, and procedure qualification.

Certification is vital for quality assurance, compliance, safety, and competitiveness, especially in demanding sectors such as aerospace, energy, marine, and manufacturing. Advanced technologies like HVOF and PTA play a key role. HVOF produces dense, hard, wear-resistant coatings for turbine parts, shafts, and components exposed to corrosion and abrasion, while PTA uses a plasma arc to melt and deposit materials with precision, often for welding or cladding in high-wear or high-temperature environments.



Thermal spraying is a surface engineering process where molten or semi-molten materials such as metals, ceramics, alloys, or polymers are sprayed onto a surface to improve properties like wear, corrosion, heat resistance, or electrical conductivity.

PROSTAR PAINTS

Implementation of ISO 17025 and Type Approval of Paint and Facilities

Prostar Paints, established in 2006 in Overport, Durban, has grown from a paint distributor into a full-scale manufacturer and formulator of high-performance coatings for residential, commercial, and industrial markets. Over nearly two decades, it has developed a strong presence by offering locally manufactured solutions tailored to South Africa's diverse environmental conditions. Its portfolio spans washable decorative interior paints, weather-resistant exterior and roof coatings, and specialist products for marine, industrial, and road-marking applications, supported by nearly a thousand product variants and in-house technical expertise.

The company is recognised for its focus on quality, sustainability, and inclusivity. All formulations are lead-free, low-VOC, and aligned with international environmental and safety standards. Prostar holds SABS approval, is a member of SAPMA, and contributes to green building initiatives. As a Level 1 B-BBEE contributor, it actively promotes transformation and diversity within the coatings industry. With over 100 years of combined staff experience and strong technical support through datasheets, selector tools, and warranties, Prostar continues to adapt and lead with integrity in the local market.

In high-stakes sectors, independent verification through ISO/IEC 17025 accreditation and Type Approval is essential. ISO/IEC 17025 ensures testing laboratories maintain technical integrity and deliver accurate, traceable results for performance tests such as adhesion, corrosion resistance, gloss, and impact resistance. Type Approval, granted by classification bodies like DNV, ABS, and Lloyd's Register, confirms that paint systems meet strict technical, safety, and regulatory standards. Together, these certifications strengthen market access, guarantee consistent product performance, and demonstrate Prostar's commitment to quality, safety, and international credibility.



CARBONTECH

ABS Approved Carbon Fibre Pipe Repair Schemes

Carbontech Composite Systems (trading as Carbontech) is a Johannesburg-based engineering firm specialising in advanced composite repair solutions for critical infrastructure, with a strong focus on pipes and pressure systems.

Founded in 2018 and headquartered in Randburg, Carbontech has positioned itself as a market leader in live, cold-applied repair technologies. Its flagship solution, the Revowrap® Composite Repair System, is a high-performance wrap designed to restore structural integrity under live conditions without the need for shutdowns. Complementing this is the Spitze HP Clamp®, capable of arresting leaks at pressures up to 200 bar and temperatures of 315 °C, along with the Revomat post-curing system and hands-on training programmes for global deployment.

With a local manufacturing capacity of up to 1 750 m² per week, Carbontech combines engineering expertise, innovative product design, and a zero-failure philosophy to offer rapid, non-intrusive, and safe solutions to high-risk industries. Its reputation for quality, reliability, and international certification reinforces its position as a trusted partner in the energy, petrochemical, power, and water sectors worldwide.

ABS-approved carbon fibre pipe repair schemes are composite repair systems certified by the American Bureau of Shipping (ABS) for use in demanding marine and offshore environments such as onboard ships, offshore platforms, and subsea pipelines. These systems provide structural reinforcement and restore integrity to damaged or degraded metallic piping, especially where traditional methods like welding or hot work are impractical or unsafe. Using high-strength carbon fibre fabric embedded in resin matrix, these cold-applied wraps offer a durable, non-intrusive solution for managing corrosion, erosion, mechanical damage, and fatigue cracking.



A large pipeline in Iraq with multiple areas of external corrosion at the intersections of a T component was rehabilitated using Revowrap, eliminating the need to replace the piping system.

What does ABS approval confirm?

- Compliance with ISO 24817, ASME PCC-2, and ABS-specific standards
- Tested mechanical, chemical, and environmental performance
- Defined pressure and temperature limits
- Compatibility with various pipe materials (e.g., carbon steel, stainless steel)
- Resistance to seawater, oil, and chemicals
- Qualified installation procedures and personnel standards

Why Use ABS-Approved Repairs?

- Eliminates the need for dry-docking or shutdown
- Enables safe, cold-applied repairs in remote or emergency conditions
- Provides cost-effective and fast alternatives to pipe replacement
- Extends asset life and enhances safety with minimal disruption



A 12" white oil pipeline with internal corrosion was safely excavated, repaired using Revowrap, and restored to service with reinforced structural integrity and corrosion protection.



COORDINATION, PROMOTION AND AWARENESS



Coordination, promotion, and awareness are vital for the Aerospace Industry Support Initiative (AISI) because they ensure that the different players in the aerospace ecosystem—government, industry, research institutions, and emerging enterprises—work together towards common objectives. Without proper coordination, efforts can easily become fragmented, leading to duplication of resources or missed opportunities. By facilitating alignment across stakeholders, AISI is able to create synergies that strengthen South Africa’s aerospace capabilities, accelerate technology development, and enhance global competitiveness.

Promotion plays a critical role in showcasing the achievements and potential of local aerospace enterprises, particularly small and medium-sized businesses that often struggle with visibility. By highlighting success stories, innovative technologies, and export opportunities, AISI helps attract investment, foster industry partnerships, and open doors to international markets. Effective promotion also builds credibility and positions South Africa as a serious player in the global aerospace value chain, which is essential for securing contracts and collaborations.

Awareness is equally important because many stakeholders—ranging from policymakers and investors to learners and entrepreneurs—need to understand the value and opportunities

within the aerospace sector. By raising awareness, AISI encourages greater participation in its programmes, promotes skills development, and inspires innovation across the supply chain. Moreover, awareness ensures that industry challenges and needs are recognised at policy level, enabling better support frameworks. In essence, coordination, promotion, and awareness are the glue that holds together the ecosystem, ensuring that AISI’s interventions are impactful, inclusive, and sustainable.

AESSA ANNUAL CONFERENCE

The Aeronautical Society of South Africa (AeSSA) Annual Conference 2024 took place from 24 to 26 July 2024 in the Western Cape. The event brought together aerospace professionals, researchers, students, and industry leaders. Organised by the AeSSA, the event provided a platform for learning, networking, and knowledge exchange among innovators and stakeholders across South Africa's aerospace sector.

At the event, the CSIR and AISI showcased collaborative aerospace projects and emerging technologies, and attendees participated in dynamic sessions featuring locally developed unmanned aerial systems, advanced propulsion and materials research, and a number of cutting-edge concepts reflecting AeSSA's commitment to nurturing South Africa's aerospace innovation capacity.

More About AeSSA

The Aeronautical Society of South Africa (AeSSA) is a professional body that advances aeronautical and aerospace science and technology in the country. It provides a platform for engineers, researchers, pilots, and students to share knowledge, foster innovation, and build skills through conferences, technical lectures, and publications, ensuring alignment with international best practices.

AeSSA also unites academia, industry, government, and international partners, while inspiring young professionals through networking and recognition programmes. By contributing to policy, promoting education, and celebrating achievements, the Society preserves South Africa's aviation heritage and drives its growth and competitiveness in the global aerospace sector.



AEROSPACE AND DEFENCE INDUSTRY DAY

The Aerospace and Defence Industry Day, hosted on 29 November 2024 by the AISI, remains a key event to foster innovation and collaboration across South Africa's aerospace and defence sectors. The event was targeted at a broad range of stakeholders, from SMMEs to large enterprises and research entities.

The day featured presentations from current AISI beneficiaries, interactive discussions addressing sector-specific challenges and opportunities, and valuable networking sessions aimed at catalysing new partnerships and beneficiary recruitment.

industrialisation. By showcasing success stories and creating space for stakeholder dialogue, the event highlighted South Africa's industrial potential and the collaborative pathways needed to drive sectoral growth and economic impact.

Events such as this play a critical role in reinforcing South Africa's strategic objectives in aerospace and defence





MARINE INDUSTRY DAY

The AISI organised a Marine Industry Day in Cape Town on 26 February 2025 in partnership with the South African Boatbuilders Export Council (SABBEX). The event convened key stakeholders from government, industry, SMMEs, and accreditation bodies to foster collaboration, share insights, and align support mechanisms tailored to the marine manufacturing sector. Through presentations, workshops, and interactive discussions, participants explored ways to enhance technology development, quality standards, and market access, aiming to boost the competitiveness and sustainability of local marine businesses.

The event highlighted the importance of standards and accreditation as essential enablers for SMMEs aiming to integrate into global supply chains. It also reaffirmed the AISI's role in aligning with government industrial policy objectives, notably industrialisation, job creation, transformation, and localisation — ultimately facilitating sustainable growth in the marine sector.





Aerospace Industry Support Initiative

an initiative of **the dtic**

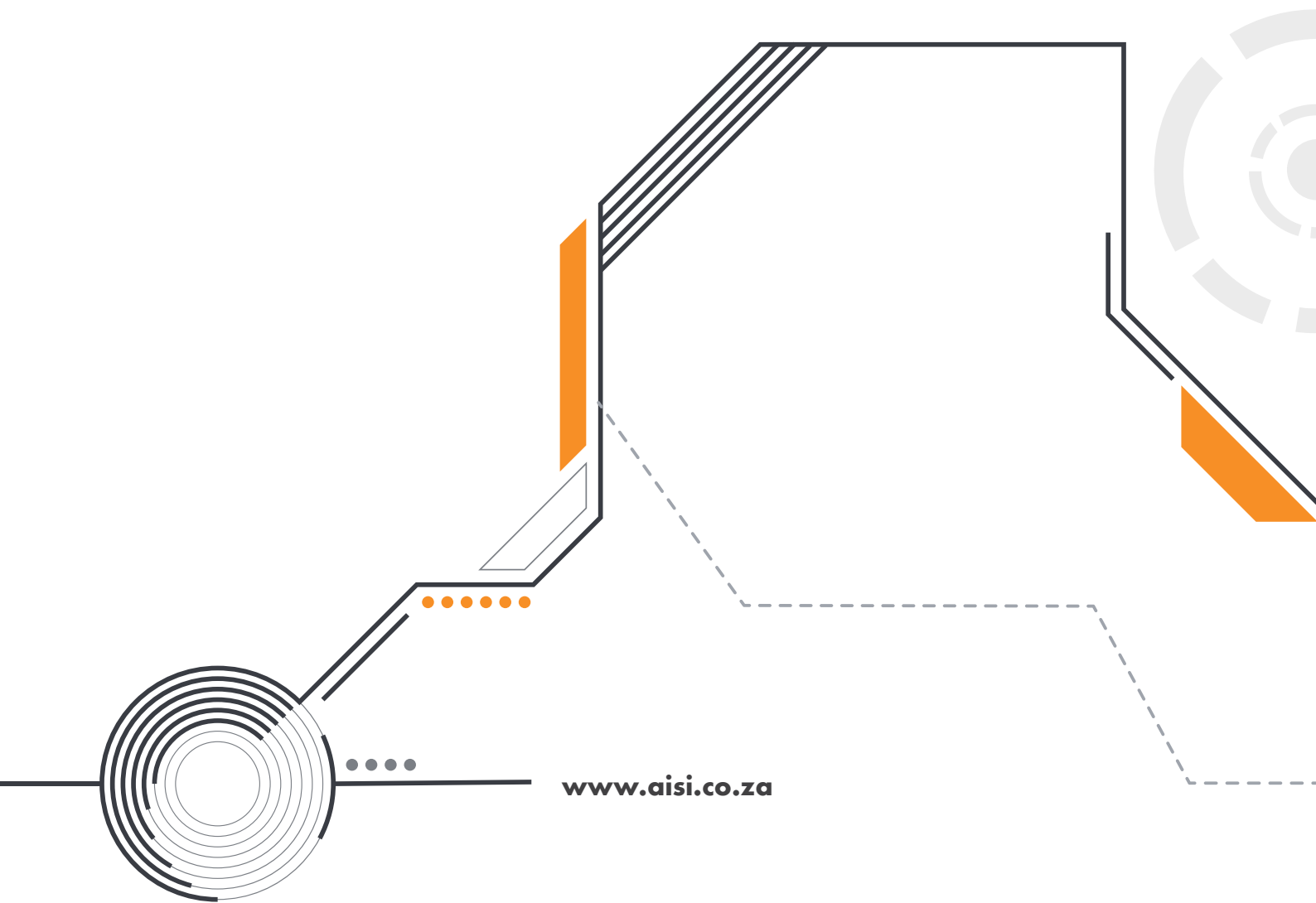

www.aisi.co.za



the dtic

Department:
Trade, Industry and Competition
REPUBLIC OF SOUTH AFRICA



CSIR
Touching lives through innovation